

---

Masters Theses

Student Theses and Dissertations

---

Spring 2009

## Time-weighted average solid-phase microextraction (TWA-SPME) for in-planta detection of chlorinated solvents

Emily Moore Sheehan

Follow this and additional works at: [https://scholarsmine.mst.edu/masters\\_theses](https://scholarsmine.mst.edu/masters_theses)



Part of the [Civil and Environmental Engineering Commons](#)

Department:

---

### Recommended Citation

Sheehan, Emily Moore, "Time-weighted average solid-phase microextraction (TWA-SPME) for in-planta detection of chlorinated solvents" (2009). *Masters Theses*. 6888.

[https://scholarsmine.mst.edu/masters\\_theses/6888](https://scholarsmine.mst.edu/masters_theses/6888)

This thesis is brought to you by Scholars' Mine, a service of the Missouri S&T Library and Learning Resources. This work is protected by U. S. Copyright Law. Unauthorized use including reproduction for redistribution requires the permission of the copyright holder. For more information, please contact [scholarsmine@mst.edu](mailto:scholarsmine@mst.edu).



TIME-WEIGHTED AVERAGE SOLID-PHASE  
MICROEXTRACTION (TWA-SPME) FOR IN-PLANTA  
DETECTION OF CHLORINATED SOLVENTS

by

EMILY MOORE SHEEHAN

A THESIS

Presented to the Faculty of the Graduate School of the  
MISSOURI UNIVERSITY OF SCIENCE AND TECHNOLOGY

In Partial Fulfillment of the Requirements for the Degree

MASTER OF SCIENCE IN ENVIRONMENTAL ENGINEERING

2009

Approved by

Joel G. Burken, Advisor  
Mark W. Fitch  
Douglas K. Ludlow

© 2009

Emily Moore Sheehan

All Rights Reserved

## ABSTRACT

Recent interest in the use of phyto-mapping for plume delineation at contaminated sites has promoted a need for new and innovative sampling techniques. Solid-phase micro-extraction (SPME) methods have been developed as a chemical analysis tool offering fast, simple, non-invasive sampling without the use of solvents. In this study SPME devices were tested for applicability for *in-planta* detection of chlorinated solvents. To evaluate the use of SPME for VOCs *in-planta* a number of integrated studies were undertaken.

Uptake profiles were developed for nine chlorinated solvents in a liquid polydimethylsiloxane (PDMS) matrix with 100  $\mu\text{m}$  Carboxene SPME fibers. Time-weighted average (TWA) sampling was conducted by exposing the SPME fiber to the chemical mixtures using three retraction lengths. Linear uptake profiles were demonstrated for 25 of the 27 of the sampling conditions. A storage experiment was conducted to determine sample retention on the SPME fiber for transport prior to analysis. It was demonstrated that all chemicals except dichloromethane are retained on the fiber for up to 24 hours. Field sampling with SPME devices was conducted at a known chlorinated solvent contaminated site using a newly designed *in-planta* sampler. Sampling with SPME fibers produced detections ranging from 5 to 234 times higher than tree core sampling.

This work demonstrates that SPME devices can be used for *in-planta* detection of a broad range of chlorinated solvents, achieving levels of detection higher than tree core sampling. With these results, SPME devices show great potential for use as a field sampling tool for *in-planta* detection of chlorinated solvents.

## ACKNOWLEDGMENTS

I would like to express my thanks to all of those who helped to make this work possible. My sincerest thanks go to my advisor, Dr. Joel G. Burken, for his guidance, his wisdom, and his endlessly encouraging spirit. He has truly been an excellent teacher and motivator and has greatly influenced my career path.

I am also especially grateful to Dr. Mark W. Fitch for the excellent instruction he provided in classroom as well as his guidance and jovial spirit outside the classroom and his service on my committee. My appreciation also goes to Dr. Douglas K. Ludlow for his service on my committee, and for coming on board so late in the process.

Thanks go to Dr. Phillip Mayer and Uli Gosewinkel (Karlson) of the Denmark National Environmental Research Institute for their contributions to this work in the area of the development of SPME technology. Thanks also to Chris Linton and Helmi Selin of Supelco for their technical support as well as providing the SPME fibers used in this work. Thanks to the National Science Foundation and the EPA Midwest Hazardous Substances Research Center for funding this work.

I would also like to express great appreciation to my lab group members: Amanda Gilbertson, Sally Breite, Jeff Weishaar, and Krishna Kumar Baduru. Their assistance and friendship was invaluable during my time as a graduate student. I will always remember fondly the hours spent in the lab as well as the fun times we shared on conference trips. Finally, I am tremendously grateful to my family and friends for their loving support and encouragement. I am particularly grateful to my parents who have instilled in me a love for learning which has guided every decision and led to all of my achievements.

## TABLE OF CONTENTS

|  | Page |
|--|------|
| ABSTRACT.....  | iii  |
| ACKNOWLEDGMENTS .....  | iv   |
| LIST OF ILLUSTRATIONS.....   | vii  |
| LIST OF TABLES.....  | viii |
| NOMENCLATURE .....   | ix   |
| <b>SECTION</b>   |      |
| 1. INTRODUCTION.....   | 1    |
| 1.1. BACKGROUND .....  | 1    |
| 1.1.1. Contaminant Fate and Transport Mechanisms in Vegetation ..... | 2    |
| 1.1.2. Current Sampling Techniques .....                             | 4    |
| 1.1.3. Solid-Phase Microextraction .....                             | 6    |
| 1.2. GOALS AND OBJECTIVES .....                                      | 7    |
| 1.2.1. Study Objectives.....   | 7    |
| 1.2.2. Hypothesis .....  | 8    |
| 2. REVIEW OF LITERATURE.....   | 9    |
| 2.1. PHYTOREMEDIATION .....  | 9    |
| 2.1.1. Phytoremediation of Volatile Organic Compounds .....          | 9    |
| 2.1.2. Tree Core Sampling.....                                       | 10   |
| 2.1.3. Contaminant Diffusion through Tree Tissue.....                | 11   |
| 2.2. SOLID-PHASE MICROEXTRACTION DEVICES .....                       | 12   |
| 2.2.1. Equilibrium Sampling .....                                    | 12   |
| 2.2.2. Time-Weighted Average Sampling.....                           | 13   |
| 2.2.3. Environmental Applications.....                               | 16   |
| 3. MATERIALS AND METHODS .....                                       | 19   |
| 3.1. FIBERS AND COMPOUNDS .....                                      | 19   |
| 3.2. SAMPLING RATE EXPERIMENT .....                                  | 19   |
| 3.2.1. Solution Preparation.....                                     | 19   |

|  |    |
|--|----|
| 3.2.2. Time-weighted Average Passive Sampling..... | 20 |
| 3.3. STORAGE EXPERIMENT .....                      | 23 |
| 3.4. FIELD SAMPLING.....                           | 24 |
| 4. RESULTS AND DISCUSSION .....                    | 28 |
| 4.1. SAMPLING RATE EXPERIMENT .....                | 28 |
| 4.1.1. Chloromethanes.....                         | 35 |
| 4.1.2. Chloroethanes.....                          | 36 |
| 4.1.3. Chloroethenes.....                          | 37 |
| 4.2. STORAGE EXPERIMENT .....                      | 37 |
| 4.3. IN-PLANTA FIELD SAMPLING .....                | 41 |
| 5. CONCLUSIONS AND RECOMMENDATIONS.....            | 46 |
| 5.1. CONCLUSIONS.....                              | 46 |
| 5.2. RECOMMENDATIONS.....                          | 47 |
| 5.2.1. Future Work .....                           | 47 |
| 5.2.2. <i>In-Planta</i> Sampler Improvements ..... | 48 |
| APPENDICES   |    |
| A. PHYSICAL PROPERTIES .....                       | 50 |
| B. TWA-SPME SAMPLING PROCEDURE .....               | 52 |
| C. TWA-SPME SAMPLING RESULTS.....                  | 56 |
| BIBLIOGRAPHY .....                                 | 63 |
| VITA.....  | 67 |



## LIST OF ILLUSTRATIONS

|  | Page |
|--|------|
| Figure 2.1. Typical SPME fiber.....  | 13   |
| Figure 2.2. Concentration profile during TWA sampling.....   | 14   |
| Figure 3.1. Preliminary design of SPME <i>in-planta</i> sampler.....                                   | 26   |
| Figure 3.2. Final design of SPME <i>in-planta</i> sampler .....  | 26   |
| Figure 4.1. SPME sampling with full fiber exposure (B) and 20% fiber exposure (C)...                   | 28   |
| Figure 4.2. Example of TWA-SPME sampling results; chloroethenes grouped by compound .....              | 30   |
| Figure 4.3. Example of TWA-SPME sampling results; chloromethanes grouped by retraction length (Z)..... | 31   |
| Figure 4.4. Chloromethane storage test results .....   | 38   |
| Figure 4.5. Chloroethane storage test results .....  | 39   |
| Figure 4.6. Chloroethene storage test results .....  | 40   |
| Figure 4.7. <i>In-planta</i> sampler and SPME device during sampling at Kellwood Site.....             | 42   |
| Figure 4.8. Field sampling results for TCE detection .....   | 43   |
| Figure 4.9. Field sampling results for PCE detection .....   | 43   |
| Figure 5.1. Design improvement for <i>in-planta</i> sampler .....                                      | 48   |

## LIST OF TABLES

|   | Page |
|---|------|
| Table 3.1. Stock solution concentrations used in the sampling rate and uptake experiments .....   | 20   |
| Table 3.2. Parameters of GC methods used in all SPME analysis .....   | 22   |
| Table 3.3. SPME storage experiment sampling parameters to evaluate the potential for field sampling and in-lab analysis .....   | 24   |
| Table 4.1. Summary of linear parameter results from TWA sampling at three diffusion path lengths .....  | 32   |
| Table 4.2. Theoretical sampling rates (ml/min) .....  | 34   |
| Table 4.3. Comparison of percent change in theoretical sampling rates (SR) with slopes of observed TWA uptake profiles for each change in diffusion path length ..... | 35   |
| Table 4.4. Trees sampled by SPME analysis at Kellwood Site.....   | 41   |
| Table 4.5. TWA-SPME parameters for <i>in-planta</i> sampling at Kellwood Site.....  | 42   |
| Table 4.6. Ratios of SPME to tree core peak responses demonstrating increased detection with SPME.....  | 44   |

**NOMENCLATURE**

| Symbol   | Description                            |
|----------|--|
| SPME     | Solid-phase Microextraction            |
| VOC      | Volatile Organic Compound              |
| $K_{ow}$ | Octanol-water Partitioning Coefficient |
| TWA      | Time-weighted Average                  |
| PDMS     | Polydimethylsiloxane                   |
| CAR      | Carboxene                              |
| DCM      | Dichloromethane                        |
| CF       | Chloroform                             |
| CT       | Carbon tetrachloride                   |
| DCA      | 1,2-Dichloroethane                     |
| TCA      | 1,1,2-Trichloroethane                  |
| PCA      | 1,1,2,2-Tetrachloroethane              |
| DCE      | cis-1,2-Dichloroethylene               |
| TCE      | Trichloroethylene                      |
| PCE      | Perchloroethylene                      |

# 1. INTRODUCTION

## 1.1. BACKGROUND

Recent research has shown that plants can take up contaminants from the subsurface, acting as biosensors for subsurface contamination. This phenomenon can be employed for contaminant detection by using existing plants as sampling points, or through new plantings in phytoremediation systems. Phytoremediation has received considerable attention in recent years because of its effective, economical, and non-invasive nature. This technology utilizes the interaction between plant species and subsurface contaminants as a remediation technique. Many laboratory studies and field applications have demonstrated that the treatment of shallow contamination of soil and groundwater by vegetation is a viable option. Treatment goals can vary including containment and sequestration, hydraulic control, application as a supplement to another technology, or complete removal of contaminants as a stand-alone remediation process. Contaminants applicable to phytoremediation are also as varied including volatile and semi-volatile organics, petroleum hydrocarbons, metals, polycyclic aromatic hydrocarbons, nutrients, and explosives.

Solid-phase microextraction (SPME) is a developing technology used for chemical analysis. The technology takes advantage of the high sorption capacity of certain polymers. By utilizing a fine metal fiber coated in a thin layer of polymer, a large surface area is created thereby providing a large volume for sorption. When the fiber is exposed to compounds of a specific chemical nature, the compounds will sorb to the polymer coating proportionally to the compound concentration and time of exposure. Other parameters that affect the rate of accumulation include temperature, barriers to

diffusion, competitive adsorption, and sorption capacity. Chemical properties that govern the interaction of compounds with the polymer coating include volatility, polarity, molecular weight, and structure.

This study represents the first attempt to apply SPME technology as a sampling technique in the field of phytoremediation. Combining SPME technology with knowledge of plant-contaminant interactions will allow for the benefits that SPME devices offer to be applied to detection of subsurface contamination without direct sampling of the groundwater. This would decrease or eliminate the need for sampling wells. SPME devices offer fast and easy sample preparation. The devices act as a highly sensitive sensor for contaminant detection, allowing for data generation that might not otherwise be possible.

Hybrid poplars have been shown to uptake and volatilize volatile organic compounds (VOCs) while SPME fibers have been shown to detect VOCs in air. It follows that SPME fibers can be used to detect VOCs in tree tissues. This study explores this possibility by evaluating the effectiveness of SPME fibers for detection and quantitative analysis of certain classes of chlorinated solvents. In addition, the use of SPME fibers for sampling *in-planta* and of tissues *in-vitro* is also explored. SPME fibers provide the potential for increased detection limits with simplified sample preparation and analysis versus traditional sampling techniques. Sampling may also offer real-time results allowing for sampling plans to be modified on-site, honing in on contaminated areas and particular hot spots.

### **1.1.1. Contaminant Fate and Transport Mechanisms in Vegetation.**

Contaminant fate has been studied in phytoremediation systems by many researchers to understand the many chemical and physical processes which combine to ultimately

provide abatement of contaminant potency in the environment. These efforts have led to the determination of five distinct mechanisms which determine contaminant fate and transport; phytostabilization, rhizodegradation, phytoextraction, phytovolatilization, and phytodegradation. Chemical and biological interactive properties predicate fate in these approaches.

Phytostabilization is the process by which contaminants are sequestered in the rhizosphere. This sequestration can be the results of contaminant interaction with the root system or microorganisms in the rhizosphere. In this process the structure of the contaminant is unchanged; however its availability is hindered, thereby lowering its toxicity. When designing these systems it is important to consider that changes to the vadose environment could result in the release of contaminants back into the soil and groundwater.

Rhizodegradation involves the metabolic degradation of contaminants by microorganisms that inhabit the rhizosphere. This degradation can be enabled or enhanced by root exudates. The fate of contaminants can vary from partial degradation to complete mineralization. By undergoing chemical transformation, the availability of the contaminant is limited. As with any contaminant degradation process, toxic intermediates and by-products are a major design consideration.

Phytoextraction, also called phytoaccumulation, begins with the uptake of contaminants through the root system from groundwater and vapor. Contaminants are then stored in an unchanged state within the plant biomass. Uptake and sequestration of contaminants within the plant biomass effectively limits the contaminant availability. Plants that have accumulated contaminant can be harvested, thereby safely removing the

contaminant from the soil and groundwater. The harvested plant matter can then be safely disposed, usually through incineration or landfill disposal.

The fourth mechanism of phytoremediation, phytovolatilization, involves the uptake of contaminants from the subsurface and release to the atmosphere through volatilization of the contaminants from the leaves and stems without transformation. As plant species vary, so do the abilities of plants to take up contaminants. The physical properties of a contaminant govern its potential for plant uptake, particularly its octanol-water partitioning coefficient. After volatilization from the plants' leaves and stems, contaminants are often degraded by photo-chemical reactions in the atmosphere at degradation rates much greater than in the subsurface.

The final mechanism of phytoremediation, phytodegradation, involves the uptake of contaminants through the root system as in phytovolatilization and phytoextraction. Rather than volatilization or sequestration of contaminants, the contaminants are metabolically degraded within the plant biomass.

The mechanism of particular interest for this study is phytovolatilization. The contaminants of interest are known to be taken up by poplar trees [1]. Poplars have been widely studied for use in phytoremediation systems because of their ease of planting, fast growth rate, large quantities of water usage, and tolerance of organics [1]. One fate that has been identified for these contaminants is volatilization from the leaves and stems. Detection of contaminants prior to volatilization is the main target of this study with the purpose to delineate groundwater pollution and determine the fate of organics in the planted system.

**1.1.2. Current Sampling Techniques.** Concentrations of contaminants in tree tissues have typically been analyzed by headspace analysis of tree core samples or by

direct measurement of the volatilization of contaminants from the transpiration stream through the use of diffusion samplers [2, 3, 4]. While these methods do provide valuable data, they each have several drawbacks. Tree core sampling requires a minimum of 24 hours of preparation time for each sample to equilibrate before analysis. As a further drawback to the tree core method, tree cores effectively sample only a very small percentage of the total tree mass. The sampling method dilutes the contaminant concentration or chemical activity in the sampling process and the methods are limited to highly volatile compounds. In addition, contaminant concentrations vary with height and radius, therefore the results from a tree core sample provide information about only the small mass of the tree sampled and may not accurately reflect the overall concentration in the tree.

The other tool commonly used for sampling of phytoremediation systems, diffusion samplers, operate by collecting contaminants volatilized from a tree's leaves and stems. Typically the transpiration stream is collected in either a sealed collar around the trunk of a tree or a bag placed over selected leaves of a tree. A negative pressure is maintained in the collection device through an attachment to a pump. The pumped air is funneled through an adsorptive material, such as activated carbon, for collection of contaminants. The air intake into the collection device is scrubbed with a carbon or tenax filter to remove the volatile contaminants from the gas flow. [4]

This type of sample collection also has several disadvantages, the greatest being the need for pumps. It is often not practical to operate pumps at remote contaminated sites which may not have buildings or electricity readily available. In addition, phytoremediation projects often operate on a low budget and with limited manpower, making the cost of operating and maintaining pumping equipment prohibitive. The time



required for analysis can also be extensive due to the complicated desorption equipment or extraction techniques required by the type of media used for sample collection, thus prohibiting on-site analysis. Another concern with this sampling technique is maintaining an adequate seal around the area of the tree to be sampled. As the surface of the plant is irregular and the device must be weather resistant, a good seal can be difficult to maintain. These sampling methods are also subject to background interferences from contaminants that might be present in the surrounding air. Also, the collection devices are often pieced together and non-uniform making confidence in the quality of construction questionable and unreliable. The materials used for construction can be susceptible to the effects of sunlight and weather. These devices may be useful for qualitative plume delineation; however their reliability for quantitative analysis is debatable.

**1.1.3. Solid-Phase Microextraction.** The sampling techniques discussed previously employ a conventional approach for sampling a quantity of environmental medium as described by Mayer, et al. [5]. This approach involves detecting the quantity of contaminant present and then calculating the concentration of contaminant. As an alternative to traditional sampling methods, equilibrium sampling techniques attempt to measure concentration in a reference phase which is brought into equilibrium with the medium, as opposed to the actual concentration in a medium. In this manner, the availability and chemical activity of a substance is directly assessed [5].

A wide range of equilibrium sampling devices have been developed. Biota have been used as monitors in aquatic environments. Dosimeters are widely used in occupational health. Semipermeable membrane devices, consisting of bags of octanol or

triolein, can be deployed in water, air, or soils [5]. SPME devices have been used in such disciplines as indoor air, food science, fragrance, and soil chemistry.

SPME technology has been used in conjunction with vegetation in several studies, including the detection of emissions from Douglas-fir, Rosemary, and Lavender [6].

Another study characterized the volatile fraction of the phloem of four pine species [7].

However, no studies have yet been conducted using SPME devices for direct detection of chlorinated solvents or other groundwater contaminants in vegetative systems. This study demonstrates the utility of SPME devices for chlorinated solvent detection and analysis in vegetative systems.

## 1.2. GOALS AND OBJECTIVES

Solid-phase microextraction technology holds the potential to serve as a greatly improved sampling technique over currently accepted methods. The goal of this research is to demonstrate the applicability of SPME devices for passive sampling of chlorinated solvents and to develop *in-planta* sampling methods. With a successful application of SPME technology to vegetative sampling of chlorinated solvents, the framework for further research into quantitative analysis by SPME devices can be established.

**1.2.1. Study Objectives.** To accomplish this goal, specific objectives were established. The objectives of the current study are to:

- Demonstrate SPME time-weighted average (TWA) sampling of chlorinated solvents and determine mass loading profiles.
- Evaluate storage potential and methods for SPME devices when sampling chlorinated solvents in the field.

- Design and test an *in-planta* sampler for use in vegetative systems and establish methods for tree core sampling.

**1.2.2. Hypothesis.** SPME fiber sampling is an alternate technology that can achieve detection limits better than traditional tree core analysis. As concentrations in tree tissues serve as an indicator for the presence of subsurface contamination, lower detection limits and decreased sample preparation time can allow for enhanced plume detection and in-field analysis for plume delineation.

## 2. REVIEW OF LITERATURE

### 2.1. PHYTOREMEDIATION

The treatment of contaminated soil and groundwater through phytoremediation has been shown to be effective, economical, and appealing to the public [1]. Because of these benefits, phytoremediation is an attractive treatment option for organic contaminants that are moderately hydrophobic. Uptake rates and mechanisms for organic contaminants are of great importance to the success of phytoremediation systems and as such have been widely studied.

**2.1.1. Phytoremediation of Volatile Organic Compounds.** Uptake rates of organic compounds by plants have been shown to largely dependent on the physical-chemical properties of the compound. Studies have shown a relationship between uptake rates and a compound's octanol-water partitioning coefficient ( $K_{ow}$ ) [8,9]. These studies have determined a moderate log  $K_{ow}$  of 1-3.5 provides the ideal range for successful plant uptake [9].

Another important parameter governing plant uptake of VOCs, recently reported by Struckhoff et al., is vapor phase transport [10]. The study found that tree core concentrations of perchloroethene (PCE) were more closely tied to soil vapor phase concentrations than to groundwater concentrations. This indicates that diffusion between tree roots and the soil vapor phase in the subsurface is an important mechanism of contaminant transport.

The fate of VOCs after plant uptake is varied and can include volatilization, sequestration, degradation, or transformation. Volatilization of TCE from hybrid poplars in measurable amounts was first demonstrated by Newman, et al. [11]. This study also

showed degradation of TCE by hybrid poplars to several known metabolic products. A study by Burken and Schnoor further investigated the volatilization of organic compounds by demonstrating the transpiration of benzene, toluene, ethylbenzene, *m*-xylene, and TCE by hybrid poplars [9]. The mass of benzene transpired during the experiment was shown to be related to the volume of water transpired. Also presented in the study was evidence of uptake and sequestration of some semi-volatile organic compounds including atrazine, phenol, nitrobenzene, aniline, and cyclotrimethylenetrinitramine (RDX).

**2.1.2. Tree Core Sampling.** The technique of sampling from trees by coring has been shown to be an effective tool for delineation of shallow groundwater contamination of chlorinated VOCs. The relationship between groundwater and tree core concentrations was first investigated by Vroblesky, Nietch, and Morris [2]. Their study showed that concentrations of contaminants in tree cores appeared to reflect the configuration of groundwater plumes. To better understand the relationship between groundwater and tree core concentrations, Ma and Burken determined partitioning coefficients between air, water, and woody biomass for several chlorinated solvents [3]. It was found that partitioning coefficients relate to physiochemical characteristics, particularly Henry's law constant and vapor pressure.

This sampling technique was applied in a field study by Schumacher, Struckhoff, and Burken [12]. The researchers successfully used tree core sampling to determine the extent of chlorinated solvent contamination at a contaminated site in an urban setting. Tree coring was also applied at three TCE contaminated sites representing three distinct climates; subhumid, semiarid, and semitropical [13]. TCE uptake was demonstrated

through tree coring in a variety of tree species and in regions where depth to groundwater ranged from less than one meter to more than seven meters.

Tree core sampling is a useful tool for plume delineation in vegetated areas however the technique does have several drawbacks and limitations. The sample of tree mass collected for analysis in the form of a tree core represents a very small percentage of the total tree mass. Results based on this non-representative sample can be subject to impacts of the natural occurrence of variations in tree tissue structure. Additionally, tree core concentrations are impacted by the uptake of recharge water into the transpiration stream [13]. Researchers have found that uptake of irrigation water or rainfall resulted in rapid dilution of TCE concentrations in the tree trunk. The same study also concluded that trees with extensive lateral root systems have the potential for interaction with larger areas of an aquifer and can produce differing contaminant concentrations in tree cores from various sides of the trunk.

**2.1.3. Contaminant Diffusion through Tree Tissue.** Following the finding of contaminant uptake and the creation of a reliable method to measure that uptake, efforts were made to more accurately understand the behavior of VOCs within the air, water, biomass system. Nietch, Morris, and Vroblesky [14] studied the mechanisms of biophysical mass transport. The researchers found that evapotranspiration is the dominant transport mechanism for trichloroethene (TCE) in baldcypress trees in the summer months when water use is high. They found that diffusive flux is the dominant transport mechanism in the winter months.

In an effort to further isolate the driving force behind TCE behavior in tree systems, Ma and Burken [15] found through both laboratory and field sampling that TCE concentrations in the transpiration stream decreased both with height and in the radial

direction, showing evidence for TCE diffusion and volatilization from leaves and stems. This study also showed a direct linear relationship between TCE concentration in tissues and exposure concentrations in the roots. As a follow up to this study, a model was developed to describe TCE fate and transport within tree systems [16]. Recent research has further refined this modeling approach by direct measurement of diffusion coefficients of VOCs in live plant tissues [17].

## 2.2. SOLID-PHASE MICROEXTRACTION DEVICES

**2.2.1. Equilibrium Sampling.** Developed by Arthur and Pawliszyn in 1990, the solid-phase microextraction device employs a small segment of fused silica fiber with a thin polymer coating for both sampling of analytes and subsequent introduction to a chromatographic system [5]. An illustration of a typical SPME device is given in Figure 2.1. The SPME fiber is enclosed in a needle housing which serves three purposes; to protect the SPME fiber coating, to provide a mechanism to introduce the fiber into a chromatographic injector interface, and to act as a diffusion path length when the SPME device is used for time-weighted average (TWA) analysis for long-term sampling [18]. SPME has been widely used in various fields of analytical chemistry including environmental chemistry, food chemistry, and biological analysis such as biological fluids, hair, and breath [19].

Mayer, et al. reported that SPME devices sorb contaminants according to three distinct uptake regimes [5]. These uptake regimes are defined by sampling time; linear sampling during short sampling times, equilibrium sampling during long sampling times, and an intermediate range between short and long sampling times [5]. During linear sampling, kinetic parameters govern the uptake rate, while during equilibrium sampling

the partitioning relationships dominate. During intermediate sampling, both kinetic and equilibrium parameters affect uptake, making calibration difficult.

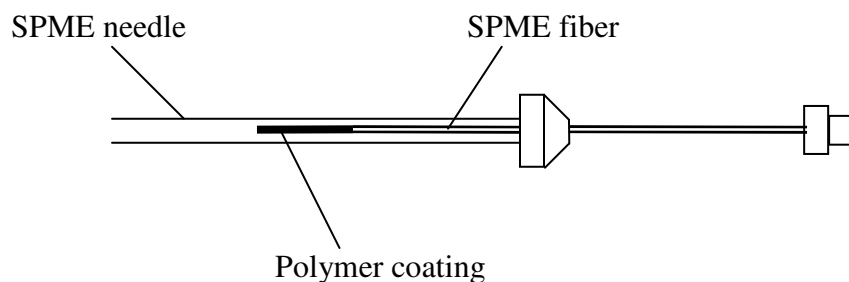

Figure 2.1. Typical SPME fiber.

Equilibrium sampling is desirable as it is more a measure of a contaminants availability and activity than conventional techniques, which measure only the quantity of contaminant present. By introducing the concept of equilibrium, SPME devices behave as a sensor for a contaminant's chemical activity [5].

**2.2.2. Time-Weighted Average Sampling.** The use of SPME devices for time-weighted average (TWA) sampling is achieved by conducting the sampling with the SPME fiber retracted a known distance inside the needle housing [20]. This method creates a barrier to diffusion and eliminates the effects of mechanical disturbances of the sampling matrix. The barrier to diffusion created by the needle housing allows sampling of contaminants in concentrations that would saturate the SPME coating if the fiber were fully exposed. The effect allows SPME devices to be used under a broader range of concentrations and sampling times.



To achieve successful TWA passive sampling using a SPME device, three basic prerequisites have been outlined [21]. The first is that the sorbent of a passive sampler must act as a zero sink for the target analytes, i.e., the concentration of the analyte at the interface of the gas phase and sorbent phase is approximately zero. This ensures that the rate of mass loading of the analyte onto the sorbent is not affected by the mass previously sorbed. This concept is illustrated in Figure 2.2, adapted from a publication by Koziel and Pawliszyn [18]. The figure shows the concentration gradient from the needle opening to the sorbent phase.

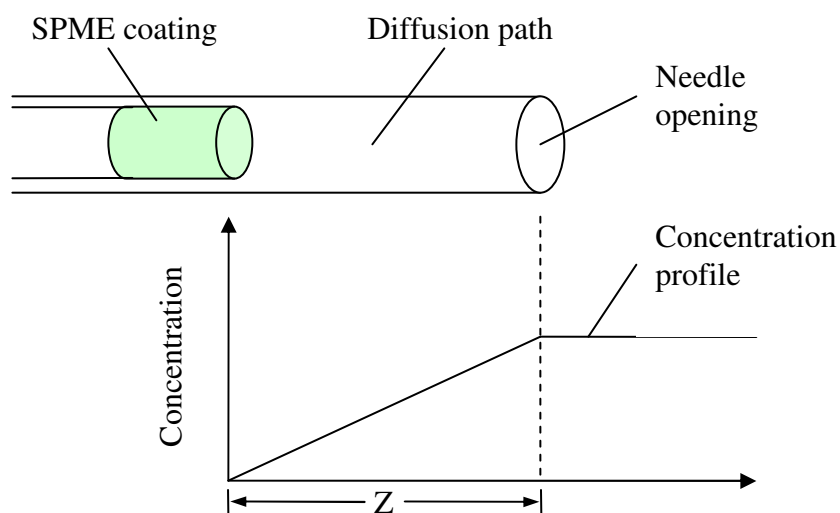

Figure 2.2. Concentration profile during TWA sampling.

The second prerequisite is that a passive sampler must respond proportionally to changing analyte concentration at the face of the device. The ability of a passive sampler to integrate high peak concentrations is directly related to the response time of the

sampler. The SPME sampler exhibits short response times enabling integration of rapidly changing concentration profiles.

The third prerequisite is that the analyte concentration at the face of the device must be equal to the bulk analyte concentration. For analyte mass loading on the SPME fiber to behave as predicted by Fick's first law of diffusion, the only resistance to analyte transport must be the stagnant air layer inside the needle housing. This suggests that a minimum air velocity and mixing is required at the face of the device. To test this assumption, one study determined SPME sampling rates of a standard gas under both static and constant velocity conditions [21]. No significant difference was found between the two conditions indicating that in practice the SPME device can be used for TWA passive sampling without considering face velocity.

Many studies have been conducted concerning the use of SPME devices for TWA sampling of volatile and semi-volatile organic compounds. A study by Khaled and Pawliszyn determined mass loading rates for a standard gas mixture of C<sub>5</sub>-C<sub>15</sub> *n*-alkanes using TWA-SPME techniques and demonstrated the use of SPME devices for field TWA sampling of indoor air at a residential house [20]. Khaled and Pawliszyn also define a term known as the sampling rate (SR) for a certain compound and SPME device needle. The sampling rate can be determined theoretically by Equation 2.1 where  $D_g$  is the diffusion coefficient of the compound in the gas phase,  $A$  is the needle opening surface area, and  $Z$  is the distance from the needle opening to the sorbent surface. The sampling rate can also be determined experimentally by Equation 2.2 where  $n$  is the amount of compound loaded on the fiber coating,  $C$  is the concentration of the compound at the needle opening, and  $t$  is the time of fiber exposure.

$$SR = D_g \frac{A}{Z} \quad (2.1)$$

$$SR = \frac{n}{Ct} \quad (2.2)$$

Further study was conducted by Chen and Pawliszyn to create an improved SPME field sampler [22]. The authors designed and tested a new holder for the SPME device. The holder allows for precise positioning of the SPME fiber inside the needle housing for TWA sampling. The study also concluded that a Teflon® cap can be used to seal the fiber from the ambient environment, preserving the sample and preventing contamination. However, the study did not test chlorinated solvents, and the storage times tested were limited to 24 hours.

**2.2.3. Environmental Applications.** Several studies have been conducted using SPME technology applied to environmental analysis. A variety of analytes, sampling media, and sampling methods have been demonstrated using SPME devices.

A study by Ter Laak, et al. used SPME devices to determine sediment-water sorption coefficient of hydrophobic organic compounds [23]. Freely dissolved concentrations of the target analytes were determined using direct exposure of the SPME fiber to sediment suspensions. The researchers concluded that the use of a passive nondepletive sampler such as the SPME device is suitable alternative to batch equilibrium methods.

Headspace SPME was used to analyze the fate and transport of dieldrin in poplar and willow trees *in vitro* in a study by Skaates, Ramaswami, and Anderson [24]. In this study dieldrin-exposed plants were blended in liquid nitrogen and stored frozen. Prior to analysis the blended plant mass was mixed with water and heated. Headspace dieldrin

extractions were performed using SPME fibers. The researchers successfully used SPME technology to quantify dieldrin mass distribution in an open plant-water hydroponic system.

A recent study by Legind, et al. demonstrated the use of automated headspace SPME for determination of chemical activity of semi-volatile organic compounds [25]. Partitioning coefficients and SPME sampling rate constants were determined for BTEX, naphthalene, and alkanes using sample matrices of liquid polydimethylsiloxane, wood, soil, and nonaqueous phase liquid. Another study by Hwang and Lee used SPME to analyze pesticide residues in Chinese herbal formulations [26]. SPME fibers were used to extract 19 organochlorine pesticides from a slurry of water and blended plant tissues [24,26].

The only application of SPME technology for *in-planta* sampling to date was conducted by Lord, et al. [27]. The concentration and translocation of pesticides within living plants was studied using SPME devices. In this study pesticide concentrations were measured from plant tissues using SPME fibers with a buffer solution barrier. Sampling was conducted from tomato, reed, and onion plants by placing a 1.5 cm long hole in the plant tissues using a 22 gauge needle at various points along the height of the plants. The hole was then filled with a buffer solution and the SPME fiber was inserted into the hole for pesticide extraction. The researchers found that in most cases pesticide concentrations decreased with plant height. The study also concluded that SPME devices offer a non-destructive and time efficient sampling method for *in vivo* sampling of plant tissues.

These studies have developed SPME technology as a valuable tool for sample collection and analysis in environmental applications. They show great promise for the

application of SPME to chlorinated solvent detection with *in-planta* sampling techniques. As of yet SPME devices are untested for use with chlorinated solvents while *in-planta* sampling techniques are just beginning to be developed. The successful application of SPME for chlorinated solvents combined with a protocol for *in-planta* sampling will create a method for the detection of subsurface contamination that can be easily and much more quickly applied in the field than traditional methods. This has the potential to greatly increase the volume of data available to researcher and engineers when delineating contaminant plumes and designing treatment systems.

### 3. MATERIALS AND METHODS

#### 3.1. FIBERS AND COMPOUNDS

SPME devices are commercially available in a variety of types with various polymer coatings. Supelco Analytical (Sigma-Aldrich Co.) offers various coating materials and thicknesses for different applications. Based upon input from their technical staff, the polymer coatings used in this study are Carboxene (CAR) and Polydimethylsiloxane (PDMS). The compounds used in this study include four classes of chlorinated solvents; chloromethanes, chloroethanes, chloroethenes, and chlorobenzenes. Within each compound class three compounds were chosen for study based on their physical properties and likelihood of contamination in the environment. All compounds and solvents used were acquired from Fisher Scientific and were reagent grade or higher purity.

#### 3.2. SAMPLING RATE EXPERIMENT

The sampling rate experiment was conducted to determine the sampling rate of a group of chlorinated solvents using SPME devices with a PDMS/Carboxene coated fiber. A summary of the physical properties of the 12 chlorinated solvents investigated is given in Appendix A.

**3.2.1. Solution Preparation.** Standard solutions were prepared using a liquid polydimethylsiloxane (PDMS) matrix. PDMS was used as a solvent to allow for long headspace sampling times with high capacity SPME fibers without the concern of headspace depletion. Solutions were prepared in 40-mL glass vials with Teflon®-lined septum caps. Appropriate amounts of each chlorinated solvent were added to liquid

PDMS to give concentrated mixtures of concentrations presented in Table 3.1. The concentrated solutions were then diluted 100-fold to give diluted stock solutions at known concentrations, also presented in Table 3.1.

Table 3.1. Stock solution concentrations used in the sampling rate and uptake experiments; all solutions were made with the analyte dissolved in PDMS oil.

| <b>Stock Solution Mixture</b> | <b>Concentrated</b> | <b>Dilute</b> |
|-------------------------------|---------------------|---------------|
| <b>Chemical Name</b>          | <b>(g/L)</b>        | <b>(mg/L)</b> |
| #1 Chloromethanes             |                     |               |
| Dichloromethane               | 0.919               | 11.3          |
| Chloroform                    | 1.04                | 12.8          |
| Carbon Tetrachloride          | 0.962               | 11.8          |
| #2 Chloroethanes              |                     |               |
| 1,2-Dichloroethane            | 0.966               | 12.1          |
| 1,1,2-Trichloroethane         | 1.00                | 12.6          |
| 1,1,2,2-Tetrachloroethane     | 1.03                | 13.0          |
| #3 Chloroethenes              |                     |               |
| cis-1,2-Dichloroethylene      | 0.985               | 14.9          |
| Trichloroethylene             | 0.99                | 15.0          |
| Perchloroethylene             | 1.06                | 16.1          |
| #4 Chlorobenzenes             |                     |               |
| Chlorobenzene                 | 0.985               | 11.8          |
| 1,2-Dichlorobenzene           | 0.971               | 11.6          |
| 1,2,4-Trichlorobenzene        | 1.00                | 12.0          |

**3.2.2. Time-weighted Average Passive Sampling.** Time-weighted average (TWA) sampling was conducted using 100  $\mu\text{m}$  Carboxene SPME fibers supplied by Supelco Analytical (Sigma-Aldrich Co., Bellafonte, Pennsylvania). All analyses were performed using an Agilent 6890N Gas Chromatograph (GC) with  $\mu\text{-ECD}$  and Merlin Microseal<sup>TM</sup> septa with SPME injection sleeve for use with SPME fibers. A Supelco

manual SPME fiber holder was used to handle the fibers, set the retraction lengths, and for insertion into the GC injection port.

Prior to sampling, all fibers were conditioned in the GC injection port. Fiber conditioning prepares the fiber for sampling by desorbing any contaminants that may be sorbed to the polymer coating. Conditioning was performed by fully exposing the SPME fiber for 10 minutes in the GC injection sleeve heated to 250 °C.

Sampling was conducted by exposing the conditioned fiber to the headspace above a solution of known concentration for a specified time period with the fiber retracted a known length within the needle housing. Sampling times performed were 30 seconds, 2, 5, 15, 30, 60, and 120 minutes for all retraction lengths and all compound mixtures. Retraction lengths ( $Z$ ) of 0.5, 1.0, and 1.5 cm were used.

Samples were prepared by placing approximately 1 mL of solution in a 22-mL glass vial with a Teflon®-lined septum cap. The septum was pierced with a needle prior to insertion of the fiber to prevent damage to the needle housing. The retraction length was set using the holder prior to insertion into the sample vial. Before sampling, the vial was rotated allowing the sample to coat the sides of the vial to refresh the headspace. Timing was started immediately after insertion of the fiber into the vial. During sampling, the vial, holder, and fiber remained motionless and at room temperature on the lab bench. Immediately after sampling, fibers were analyzed by GC- $\mu$ ECD. The parameters of the GC methods used for each chemical mixture are outlined in Table 3.2. A detailed procedure for TWA-SPME sampling is provided in Appendix B.

One complete data set of each chemical group and retraction length consisted of TWA sampling conducted at all sampling times from 30 seconds to 2 hours. A full data



set was completed using a single vial and sample of PDMS solution and a single SPME fiber. A data set was begun by fiber conditioning, followed by sampling for 30 seconds and GC analysis, followed immediately by conditioning, sampling for 2 minutes, and analysis. This procedure was repeated until all sampling times up to 2 hours were completed using a single fiber and sample vial.

Table 3.2. Parameters of GC methods used in all SPME analysis.

|                      | <b>Chloro-<br/>methanes</b> | <b>Chloro-<br/>ethanes</b> | <b>Chloro-<br/>ethenes</b> | <b>Chloro-<br/>benzenes</b> |
|----------------------|-----------------------------|----------------------------|----------------------------|-----------------------------|
| <b>Inlet</b>         |                             |                            |                            |                             |
| Mode                 | Splitless                   | Splitless                  | Splitless                  | Splitless                   |
| Injection Port (°C)  | 250                         | 250                        | 250                        | 250                         |
| Pressure (psi)       | 6.39                        | 8.00                       | 8.00                       | 9.00                        |
| Total Flow (mL/min)  | 4.8                         | 5.0                        | 5.0                        | 4.5                         |
| <b>Column</b>        |                             |                            |                            |                             |
| Mode                 | Constant P                  | Constant P                 | Constant P                 | Constant P                  |
| Pressure (psi)       | 6.39                        | 8.00                       | 8.00                       | 9.00                        |
| Flow (mL/min)        | 1.5                         | 2.0                        | 2.0                        | 1.3                         |
| Average Velocity     | 26                          | 32                         | 32                         | 28                          |
| <b>Oven</b>          |                             |                            |                            |                             |
| Initial (°C)         | 30                          | 30                         | 50                         | 150                         |
| Hold Time (min)      | 6                           | 1.5                        | 2                          | 6                           |
| Ramp (°C/min)        | 0                           | 20                         | 20                         | 0                           |
| Final (°C)           | 30                          | 100                        | 100                        | 150                         |
| Runtime (min)        | 6                           | 6                          | 6                          | 6                           |
| <b>Detector</b>      |                             |                            |                            |                             |
| Heater (°C)          | 250                         | 250                        | 250                        | 250                         |
| Makeup Flow (mL/min) | 60                          | 60                         | 60                         | 60                          |

While using a single fiber, vial, and solution sample for an entire TWA data set created consistency of sampling conditions between each sampling event, it also created the potential for depletion of the solution sample as mass was removed by each sampling

event. Equilibrium sampling conducted before and after sampling of each TWA data set, to verify that the sample solution and headspace were not depleted during TWA sampling. Equilibrium sampling was conducted by fully exposing a conditioned PDMS SPME fiber in the headspace above the sample solution for 4 minutes. Analysis was performed using the same GC methods as the TWA samples. If the peak response from equilibrium sampling conducted before and after each TWA data set were within 5% , the headspace in the vial was accepted to not be depleted by TWA sampling.

### 3.3. STORAGE EXPERIMENT

Sample retention on SPME fibers was tested to assess the usefulness of SPME devices for field sampling. For SPME devices to be useful for field sampling without the use of a portable GC, the sample collected on the SPME fiber must be retained for a period of time long enough to allow for transport to a laboratory under specific storage conditions. A field sampling scenario was simulated in the lab by dosing SPME fibers then storing them following the procedure that would be used in the field.

Dosed fibers were stored in their original packaging supplied by Supelco. For each compound group, sampling parameters were chosen based on the results of the sampling rate experiments. Exposure time and retraction length were chosen to ensure optimum GC response. Sampling parameters for each compound group are given in Table 3.3. Fibers were conditioned, dosed, and analyzed three times in sequence to achieve a baseline for comparison. The fibers were then conditioned and dosed a fourth time for storage. After dosing, the fibers were immediately capped with a Teflon® cap and placed in storage boxes. Fibers were stored for varying lengths of time ranging from 30 minutes to 48 hours. After storage, the fibers were analyzed by GC using the same

methods as prior to storage. The fibers were then immediately conditioned, dosed and analyzed one final time.

Table 3.3. SPME storage experiment sampling parameters to evaluate the potential for field sampling and in-lab analysis.

| <b>Compound Group</b> | <b>Retraction Length<br/>(cm)</b> | <b>Sampling Time<br/>(min)</b> | <b>Storage Times<br/>(hr)</b> |
|-----------------------|-----------------------------------|--------------------------------|-------------------------------|
| Chloromethanes        | 0.5                               | 2                              | 24, 48                        |
| Chloroethanes         | 0.5                               | 5                              | 24, 48                        |
| Chloroethenes         | 0.5                               | 5                              | 2, 5, 10, 24, 48              |

### 3.4. FIELD SAMPLING

Field sampling was conducted at the Kellwood Site (OU2) of the Riverfront Superfund Site in New Haven, Missouri, located approximately 50 miles west of St. Louis, Missouri. The subsurface chlorinated solvent contamination at the Riverfront Superfund Site (OU1) and at the Kellwood Site was previously investigated using tree core sampling by Schumacher, Struckhoff, and Burken [12]. The Kellwood site is the location of a current aluminum manufacturing facility. PCE was used at this site as a cleaning solvent and disposed of on the ground and into the sanitary sewer system [28]. Previous tree corings have shown PCE and TCE contamination of the soil and groundwater at this site.

Tree cores were taken using a 0.169 x 6-in. increment boring tool as previously noted [12]. Cores were immediately transferred to a 22-mL vial and capped with a Teflon®-lined septum cap. The samples were stored for 24 hours at room temperature before analysis to allow equilibration between the vial headspace and the tree tissue.

Sampling of the tree using the SPME fibers was done using the bore-hole remaining in the tree after the core was extracted, or tree core void space. A SPME *in-planta* sampler was designed and manufactured for this purpose. The *in-planta* sampler was designed with four objectives in mind. The *in-planta* sampler should; (1) be constructed of an inert material, (2) be rugged and reusable, (3) seal the tree core hole to prevent mass transport between the tree core void space and the external surroundings, and (4) provide support for the SPME fiber so that it does not touch the tree mass inside the tree core hole and will not easily break if bumped from the outside.

The design for the sampler used for the manufacture of a prototype resembles a plug and is designed to fit in the tree core hole, as shown in Figure 3.1. The sampler has a cylindrical shaft with an outer diameter that fits the tree core hole. The end of the shaft has a larger diameter which both helps to create a seal around the tree core hole and provides finger grip for inserting and removing the sampler from the tree. The sampler was designed with a hole through the center with an inner diameter that fits the outer diameter of the needle housing of the SPME fiber. This inner hole expands at the base to a diameter large enough to house the top portion of the SPME fiber to provide support for the fiber. Prototypes were made of aluminum and Teflon®. Construction materials were chosen for ease of manufacture, inert chemical nature, and accessibility. All prototypes were produced by Steve Gable, Missouri S&T Civil Engineering Machine Shop.

Manufacture of the initial design of the *in-planta* sampler from aluminum proved to have several problems, the greatest of which being the difficulty in drilling a hole for the SPME fiber of the required diameter and length. A prototype was also designed entirely of Teflon®. However, the Teflon® model proved to be difficult to maintain firmly in the tree bore-hole. The solution implemented was to drill a larger diameter hole

through the center of the aluminum sampler and insert a Teflon® sleeve into the hole to act as a ferrule and provide a seal and firm support for the sampler. This redesign of the *in-planta* sampler is shown in Figure 3.2 as a cross-section of the sampler. The new design also featured screw threading on the outside of the shaft to allow for easier insertion into the tree core hole. This final design proved to provide a good seal and support for the SPME fiber while also being rugged and reusable. The SPME *in-planta* sampler was designed by Dr. Joel G. Burken and the author, with manufacturing input from Steve Gabel.

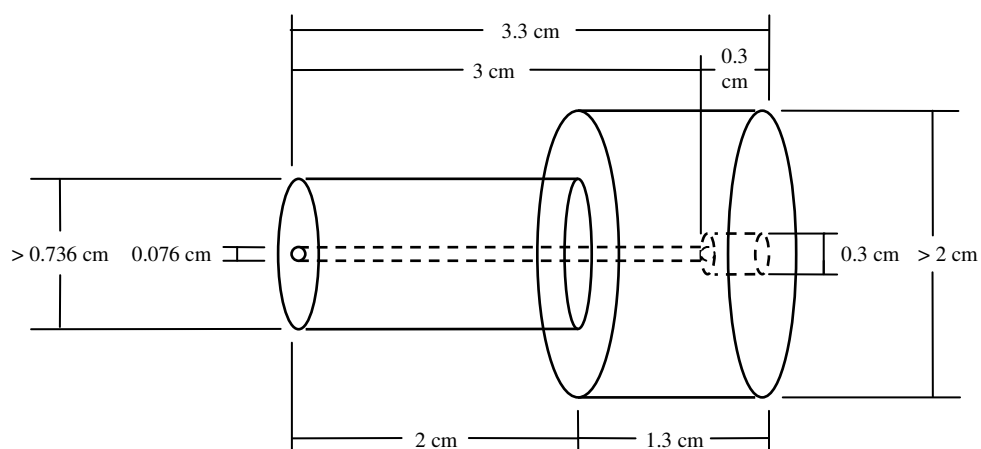

Figure 3.1. Preliminary design of SPME *in-planta* sampler.

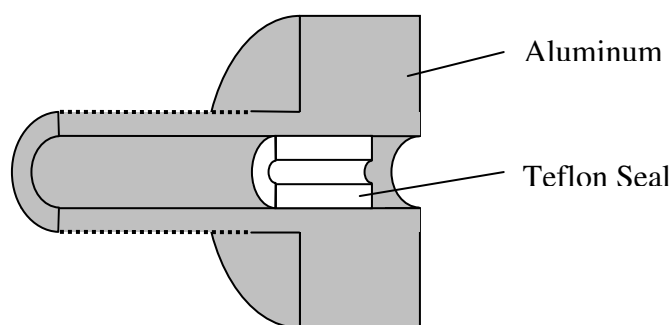

Figure 3.2. Final design of SPME *in-planta* sampler (not to scale).

Tree cores were taken from the trunk approximately one foot above the ground surface. Six tree cores were taken from five individual trees. All six tree cores were collected prior to sampling with the SPME device. Following the collection of tree cores, the *in-planta* sampler was inserted into the tree core void space. The retraction distance of the SPME fiber was set prior on insertion into the *in-planta* sampler. The sampling time began when the SPME device was inserted into the *in-planta* sampler. Sampling was conducted for approximately 75 minutes. After sampling was complete, the SPME devices were removed from the *in-planta* samplers, capped with a Teflon® cap, and stored in the storage boxes. The SPME fibers were then stored at room temperature overnight before GC analysis in the ERC laboratories at Missouri S&T.

Analysis was conducted using the GC method for chloroethenes, described in Table 3.2. Immediately after analysis, each fiber was dosed using the previously described method for TWA sampling with exposure to the chloroethene standard followed by analysis by GC. This step served to check for damage to the fiber caused during field sampling or transport. Fiber integrity was confirmed comparing GC results with previous analyses under the same conditions. Tree cores were analyzed using a 0.1 mL headspace injection used in standard tree core analysis.

## 4. RESULTS AND DISCUSSION

### 4.1. SAMPLING RATE EXPERIMENT

Previous unpublished work by Dr. Joel G. Burken has shown that sampling of chlorinated solvents using full exposure of the CAR SPME fiber produces non-linear results, as shown in Figure 4.1. Results obtained demonstrate that at longer sampling times, sorption of the analyte on the SPME fiber is stagnated. It is speculated that the high sorption capacity of the polymer coating results in sample depletion as non-linear diffusion from the plant becomes rate-limiting to fiber uptake. To prevent sample depletion, TWA sampling was tested to provide a barrier to contaminant diffusion and sorption to the SPME fiber. TWA sampling was conducted for a mixtures of chlorinated solvents using SPME devices to determine the applicability of SPME for detection of several chemical groups and to identify the response to various sampling times and diffusion path lengths.

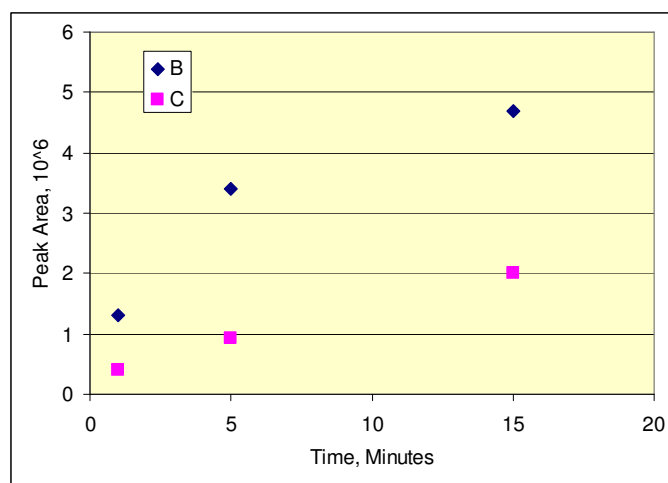

Figure 4.1. SPME sampling with full fiber exposure (B) and 20% fiber exposure (C).

Typical examples of the results from the sampling rate experiments are given in graphical form in Figures 4.2 and 4.3. Complete results of the sampling rate experiments are given in Appendix C. Each data set was plotted as sampling time versus peak area. Data is presented in two configurations for each chemical group. The first set of plots displays each compound individually and compares the three diffusion path lengths; 0.5, 1.0, and 1.5 cm. The second set of plots compares the three compounds in the chemical group for a single diffusion path length. A linear trend line was applied to each data set. A summary of the resulting parameters of the linear relationships is shown in Table 4.1. Each data set was determined to be linear if the resulting  $R^2$  value was greater than 0.96. Results for the chlorobenzene group are not shown. The chlorobenzene compounds were not detected by GC analysis after exposure by TWA-SPME sampling. This may indicate that the Carboxene fibers used in this study are not useful for the chlorobenzene group due to irreversible binding or reactivity with the fiber materials.

Equilibrium sampling was conducted before and after each TWA data set as a control on solution sample depletion. Results of the equilibrium sampling are reported as a ratio of the final peak area ( $PA_f$ ) to the initial peak area ( $PA_0$ ) for each set of TWA results. The minimum value of  $PA_f/PA_0$  is reported for each compound group in Figures 4.2 and 4.3 and in Appendix C.



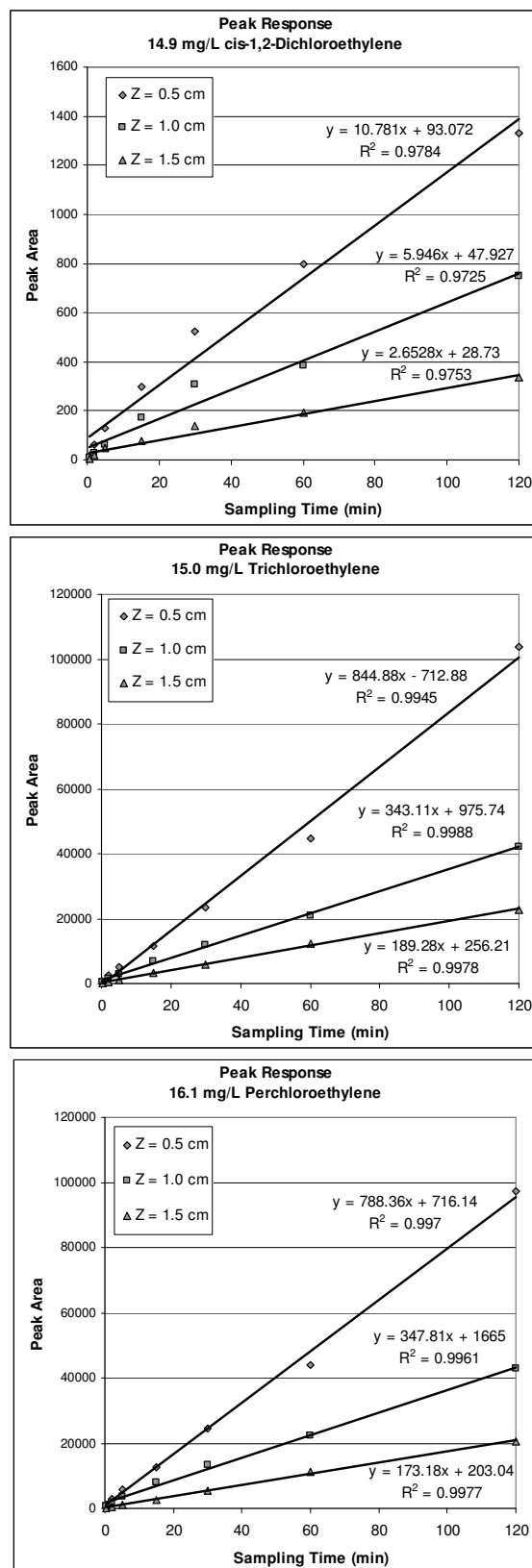

Figure 4.2. Example of TWA-SPME sampling results; chloroethenes grouped by compound.  $PA_f/PA_0 > 0.99$  for all data sets.

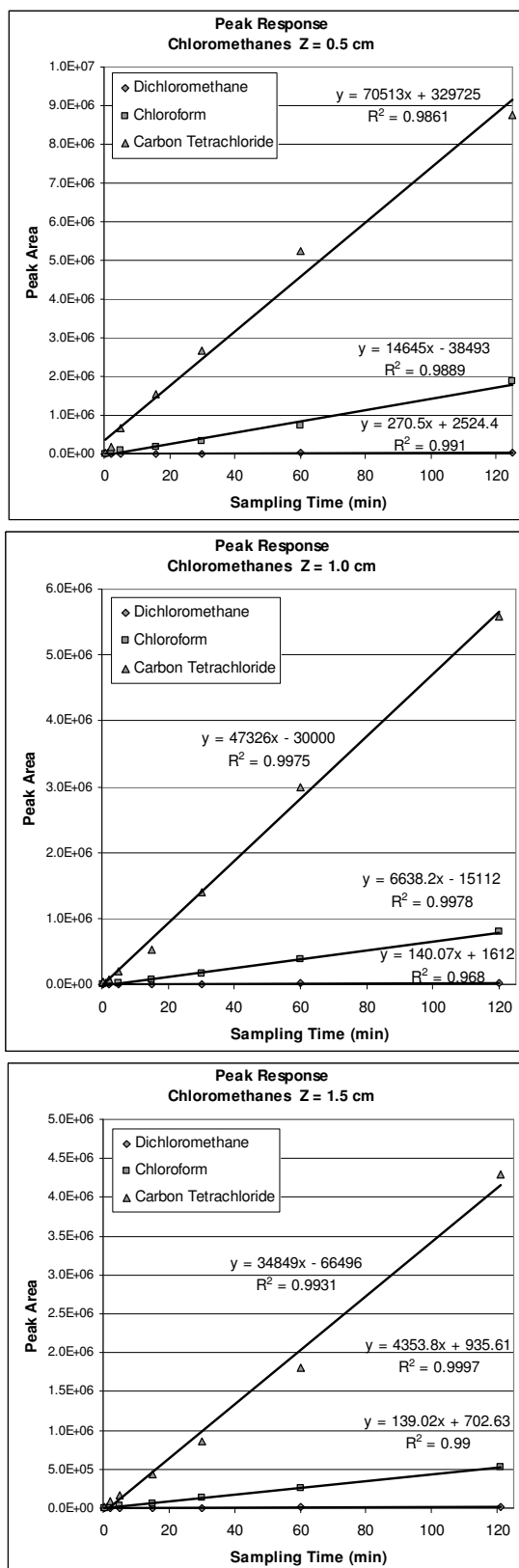

Figure 4.3. Example of TWA-SPME sampling results; chloromethanes grouped by retraction length (Z).  $PA_f/PA_0 > 0.90$  for all data sets.

Table 4.1. Summary of linear parameter results from TWA sampling at three diffusion path lengths.

|                                  | Z = 0.5 cm | Z = 1.0 cm | Z = 1.5 cm |
|----------------------------------|------------|------------|------------|
| <b>Chloromethanes</b>            |            |            |            |
| <b>Dichloromethane</b>           |            |            |            |
| R <sup>2</sup>                   | 0.9910     | 0.9680     | 0.9900     |
| Slope                            | 270.5      | 140.07     | 139.02     |
| Y-intercept                      | 2524.4     | 1612       | 702.63     |
| <b>Chloroform</b>                |            |            |            |
| R <sup>2</sup>                   | 0.9889     | 0.9978     | 0.9997     |
| Slope                            | 14,645     | 6638.2     | 4353.8     |
| Y-intercept                      | -38,493    | -15,112    | 935.61     |
| <b>Carbon Tetrachloride</b>      |            |            |            |
| R <sup>2</sup>                   | 0.9861     | 0.9975     | 0.9931     |
| Slope                            | 70,513     | 47,326     | 34,849     |
| Y-intercept                      | 329,725    | -30,000    | -66,496    |
| <b>Chloroethanes</b>             |            |            |            |
| <b>1,2-Dichloroethane</b>        |            |            |            |
| R <sup>2</sup>                   | 0.9521*    | 0.9874     | 0.9746     |
| Slope                            | 43.459     | 32.973     | 25.217     |
| Y-intercept                      | 495.7      | 242.54     | 231.32     |
| <b>1,1,2-Trichloroethane</b>     |            |            |            |
| R <sup>2</sup>                   | 0.956*     | 0.9942     | 0.995      |
| Slope                            | 25.973     | 21.222     | 14.351     |
| Y-intercept                      | 246.34     | 67.458     | 24.259     |
| <b>1,1,2,2-Tetrachloroethane</b> |            |            |            |
| R <sup>2</sup>                   | 0.9725     | 0.9937     | 0.9984     |
| Slope                            | 41.862     | 28.831     | 22.373     |
| Y-intercept                      | 353.87     | 248.58     | 66.892     |
| <b>Chloroethenes</b>             |            |            |            |
| <b>Cis-1,2-Dichloroethylene</b>  |            |            |            |
| R <sup>2</sup>                   | 0.9784     | 0.9725     | 0.9753     |
| Slope                            | 10.781     | 5.946      | 2.6528     |
| Y-intercept                      | 93.072     | 47.927     | 28.73      |
| <b>Trichloroethylene</b>         |            |            |            |
| R <sup>2</sup>                   | 0.9945     | 0.9988     | 0.9978     |
| Slope                            | 844.88     | 343.11     | 189.28     |
| Y-intercept                      | -712.88    | 975.74     | 256.21     |
| <b>Perchloroethylene</b>         |            |            |            |
| R <sup>2</sup>                   | 0.997      | 0.9961     | 0.9977     |
| Slope                            | 788.36     | 347.81     | 173.18     |
| Y-intercept                      | 716.14     | 1665       | 203.04     |

\* Non-linear response

Of the results shown in Table 4.1, two of the compounds have  $R^2$  values which fall below the 0.96 limit for linearity. The two points occurred in the chloroethane group sampling at a  $Z = 0.5$  cm. These results indicate that these sampling events were not conducted in accordance with the prerequisites for successful TWA passive sampling as outlined by Chen and Pawliszyn [21]. The graphs of these data sets, given in Appendix C, Figure C.3, indicated that the breakdown of linearity occurred at the 125 minute sampling time. Given that the non-linearity occurred at the sampling time corresponding to the highest amount of compound sorbed on the SPME fiber, the most likely cause of the non-linearity is either sample depletion or sorbent coating saturation. Non-linearity resulting from sorbent coating saturation represents a violation for the first prerequisite for TWA sampling; the sorbent material must act as a zero sink for the target analyte. Sample depletion represents a violation of the third prerequisite for TWA sampling; analyte concentration at the face of the device must be equal to the bulk analyte concentration. Results of the equilibrium sampling for dichloroethane and trichloroethane conducted before and after each TWA data set show sample depletion of 11% and 12% respectively, indicating that the non-linearity within this data set was most likely the result of sample depletion of the analyte and a change in the gas phase concentration over the sampling period. This indicates that the approach of TWA for dichloroethane and trichloroethane may be possible, but this method of evaluating the application was not sufficient to draw such a conclusion.

The theoretical sampling rate for each compound was determined using Equation 2.1 for the three diffusion path lengths. The values of the diffusion coefficient used in the calculations for each compound are given in Appendix A. Rates are calculated using a needle opening area of  $0.00086 \text{ cm}^2$ . The theoretical sampling rates are given in Table

4.2. These rates represent the theoretical volume of the sampling media that is sampled per minute of exposure to the SPME fiber. The results show that the theoretical sampling rate is directly proportional to molecular weight and decreases with diffusion path length, as is expected from earlier research with other compounds by Khaled and Pawlizyn [20].

Table 4.2. Theoretical sampling rates (ml/min). Corresponds to the volume of media sampled per minute [20]; calculated from Equation 2.1; diffusion coefficients given in Appendix A.

|                           | Z = 0.5 cm | Z = 1.0 cm | Z = 1.5 cm |
|---------------------------|------------|------------|------------|
| Chloromethanes            |            |            |            |
| Dichloromethane           | 0.011      | 0.0057     | 0.0038     |
| Chloroform                | 0.0094     | 0.0047     | 0.0031     |
| Carbon Tetrachloride      | 0.0085     | 0.0042     | 0.0028     |
| Chloroethanes             |            |            |            |
| 1,2-Dichloroethane        | 0.0094     | 0.0047     | 0.0031     |
| 1,1,2-Trichloroethane     | 0.0085     | 0.0042     | 0.0028     |
| 1,1,2,2-Tetrachloroethane | 0.0077     | 0.0039     | 0.0026     |
| Chloroethenes             |            |            |            |
| cis-1,2-Dichloroethylene  | 0.0097     | 0.0049     | 0.0032     |
| Trichloroethylene         | 0.0086     | 0.0043     | 0.0029     |
| Perchloroethylene         | 0.0078     | 0.0039     | 0.0026     |

The data presented in Table 4.2 demonstrate a uniform decrease of roughly 50% and 33% in theoretical sampling rate when the diffusion path length is increased from 0.5 cm to 1.0 cm and from 1.0 cm to 1.5 cm, respectively. Theory suggests that the same proportions should hold true for the slopes of the observed uptake profiles generated though TWA sampling. A comparison of these results is giving in Table 4.3.

Table 4.3 shows a general adherence to changes in slope with changes in diffusion path length as predicated by the theoretical sampling rate with a few exceptions. Several factors may contribute to these deviations including potential chemical interactions such

as competitive sorption, loss of mass through sorption to the needle housing or other surfaces, or slight differences in chromatographic peak integrations. These deviations are discussed by chemical group in the sections that follow. While deviations of the slope-path length relationship remain as a topic of future studies, linearity of the uptake profile under TWA sampling conditions is clearly demonstrated through this work.

Table 4.3. Comparison of percent change in theoretical sampling rates (SR) with slopes of observed TWA uptake profiles for each change in diffusion path length.

| Change in Z               | 0.5 cm to 1.0 cm |       | 1.0 cm to 1.5 cm |       |
|---------------------------|------------------|-------|------------------|-------|
|                           | SR               | Slope | SR               | Slope |
| <b>Chloromethanes</b>     |                  |       |                  |       |
| Dichloromethane           | 48.2%            | 48.2% | 33.3%            | 0.75% |
| Chloroform                | 50.0%            | 54.7% | 34.0%            | 34.4% |
| Carbon Tetrachloride      | 50.6%            | 32.9% | 33.3%            | 26.4% |
| <b>Chloroethanes</b>      |                  |       |                  |       |
| 1,2-Dichloroethane        | 50.0%            | 24.1% | 34.0%            | 23.5% |
| 1,1,2-Trichloroethane     | 50.6%            | 18.3% | 33.3%            | 32.4% |
| 1,1,2,2-Tetrachloroethane | 49.4%            | 31.1% | 33.3%            | 22.4% |
| <b>Chloroethenes</b>      |                  |       |                  |       |
| cis-1,2-Dichloroethylene  | 49.5%            | 44.8% | 34.7%            | 55.4% |
| Trichloroethylene         | 50.0%            | 59.4% | 32.6%            | 44.8% |
| Perchloroethylene         | 50.0%            | 55.9% | 33.3%            | 50.2% |

**4.1.1. Chloromethanes.** The effect of increased diffusion path length can be seen in the first set of plots for the chloromethane group, shown in Figure C.1. The change of diffusion path length from 0.5 cm to 1.0 cm produced the expected change of 48% in slope based on theory demonstrated in the theoretical sampling rate. However, the peak area responses of dichloromethane (DCM) at Z = 1.0 cm and Z = 1.5 cm are closely matched, with slopes of 140 and 139 respectively, indicating that diffusion path length is not the only parameter governing uptake. There may be mass transfer limitations

competing with SPME fiber sorption such as sorption to other materials such as the needle housing. This competitive sorption dynamic is not considered in this study.

Another possible explanation may be the physical properties of DCM. DCM has the smallest molecular weight and the largest diffusion coefficient of all the compounds tested. These factors may contribute to the decreased effect of diffusion path length to the fast moving DCM molecules after breakthrough of the needle housing opening. It should also be noted that the  $R^2$  value of the uptake profile for DCM at  $Z = 1.0$  cm is close to the limit for linearity, with a value of 0.968. Given this circumstance the similar slopes may also be the result of sample depletion, but the exact reason for the slope similarity between  $Z = 1.0$  and 1.5 was not determined in this study.

The effect of increased diffusion path length is most clearly seen in the chloromethane group in the peak response of chloroform (CF). A uniform change in uptake resulting from an increase in path length of 0.5 cm is demonstrated in both the change from 0.5 cm to 1.0 cm and from 1.0 cm to 1.5 cm. The two changes in diffusion path lengths resulted in a decrease in the slope of approximately 55% and 34%. This indicates that the uptake of CF on the SPME fiber is predominantly diffusion controlled.

The results for carbon tetrachloride (CT) show the effects of decreased uptake with increased diffusion path length but not to extent which would be expected by theory. The two changes in diffusion path lengths resulted in a decreased uptake of approximately 33% and 26%, less than the 50% and 33% predicted. This indicates that the effects of diffusion for CT are greater than for DCM but less than CF.

**4.1.2. Chloroethanes.** As with the carbon tetrachloride peak response, the three compounds of the chloroethane group exhibit the effects of increased diffusion path length as a decrease in uptake but to a lesser extent than predicted by theory. This may

indicate a similarity in chemical activity and the interaction with the SPME fiber between CT and the chloroethane group.

**4.1.3. Chloroethenes.** All three mass loading profiles in this group exhibit the trend of decreased uptake response with increased diffusion path length. However, unlike the chloroethane group, all of the compounds in the chloroethene group display a decrease in uptake with an increase in diffusion path length greater than predicted by theory. The response of TCE and PCE shows a decrease in uptake from  $Z = 0.5$  cm to  $Z = 1.0$  cm of 59% and 56% respectively, and from  $Z = 1.0$  cm to  $Z = 1.5$  cm of 45% and 50%. These responses are significantly greater than the 50% and 33% predicted by theory and suggests that there may be an additional factor governing the rate of diffusion or sorption of these two compounds which is less evident in the response of 1,2-dichloroethylene. Possible factors include sorption of the compound to the surface of the needle housing, or preferential sorption of dichloroethylene over these two compounds.

These sampling rate experiments have demonstrated linearity of compound sorption on the SPME fiber with respect to exposure time. However, the effect of diffusion path length on the slope of the uptake profile is not fully understood. Further study is needed to isolate the governing parameters of this relationship. The effects of sorption of the analyte to the needle housing, competitive sorption on the SPME fiber, as well as environmental considerations such as temperature and media mixing must be considered to fully develop a contaminant uptake model.

## 4.2. STORAGE EXPERIMENT

Sample retention of the SPME fiber was analyzed at storage times of 24 and 48 hours at ambient temperatures for all the compound groups. These storage times were



chosen to encompass the expected travel time from a field site to a laboratory and to include additional storage time in a lab prior to analysis. A more comprehensive series of tests including storage times of 2, 5, and 10 hours was conducted for the chloroethene group as these are the contaminants of interest at the proposed field site. Prior to storage, each fiber was dosed and analyzed a minimum of three times to give a baseline for the fiber. The error bars in the results indicate the standard deviation of the baseline analyses for each fiber.

Results of the tests of chloromethane compounds, shown in Figure 4.4, indicate retention of all the compounds is maintained at 24 hours of storage. At 48 hours, retention of carbon tetrachloride and chloroform is maintained; however, some loss of dichloromethane is shown.

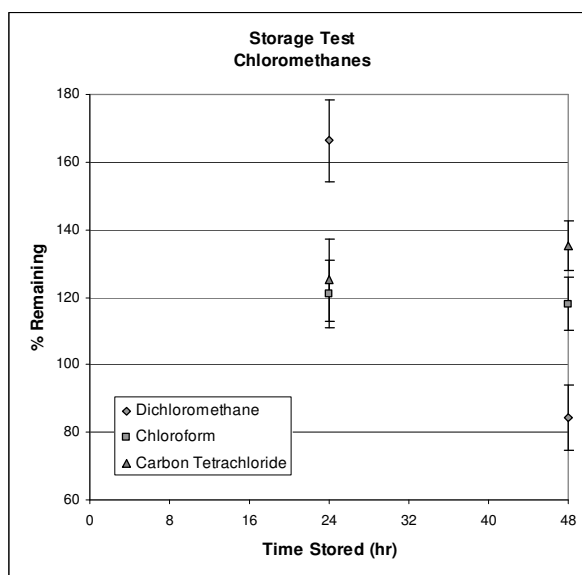

Figure 4.4. Chloromethane storage test results. Error bars represent standard deviation of 3 baseline analyses of the fiber for time stored = 24 hr and 5 baseline analyses of the fiber for time stored = 48 hr.

As shown in Figure 4.5, results of the test of chloroethane compounds also show adequate retention of all compounds at 24 hours of storage. At 48 hours of storage, retention decreases of 85% to 70% are experienced, with the greatest loss being in 1,2-dichloroethane.

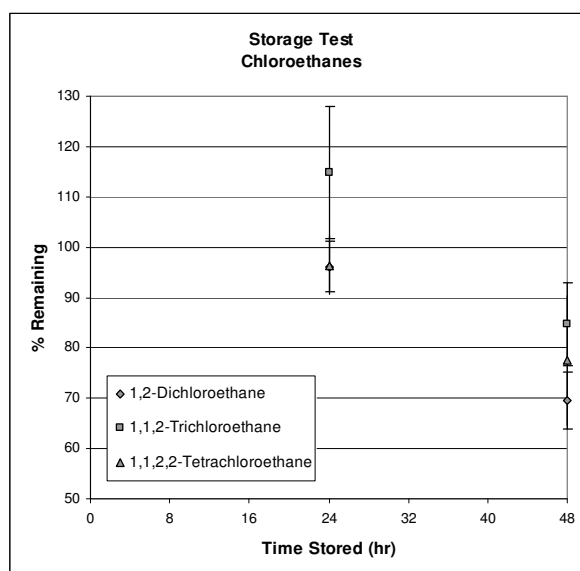

Figure 4.5. Chloroethane storage test results. Error bars represent standard deviation of 3 baseline analyses of the fiber for time stored = 24 hr and 4 baseline analyses of the fiber for time stored = 48 hr.

Results of the storage tests of the chloroethene group, shown in Figure 4.6, indicate adequate retention of TCE through the 48-hour storage time. Retention of PCE is shown to persist through 24 hours of storage; however, losses are experienced at 48 hours of storage. Losses of DCE from the SPME fiber are shown to significantly occur within 2 hours of storage and retention decreases to only 15% at 48 hours of storage.

These results indicate that when a dosed CAR/PDMS SPME fiber is capped with a Teflon® cap and stored in the packaging provided by the manufacturer, retention of

every compound analyzed, with the exception of DCE, can be expected with 24 hours of storage. At 48 hours of storage, sample retention on the SPME fiber was shown to be reliable only for chloroform, carbon tetrachloride, and trichloroethylene. Retention of DCE on the SPME fiber cannot be assured for even the minimum tested storage time of 2 hours. Therefore analysis of DCE using the CAR/PDMS SPME fibers must be carried out immediately after dosing of the fiber or an alternative method of storage must be used, such as cold storage of the fibers. Such alternate storage methods should be the subject of future evaluations.

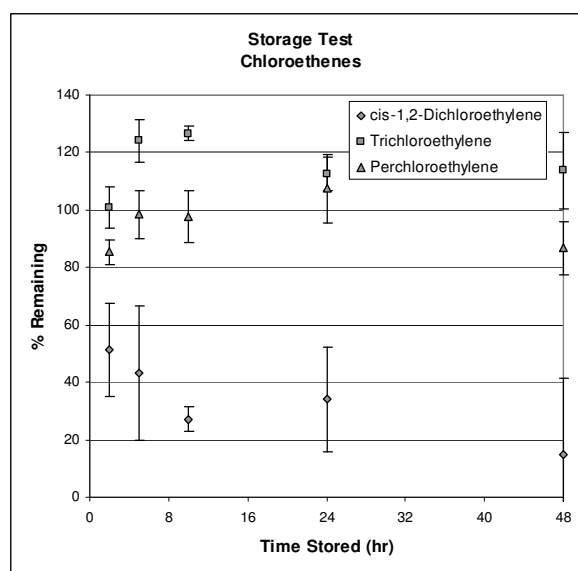

Figure 4.6. Chloroethene storage test results. Error bars represent standard deviation of 4 baseline analyses of each fiber for each time stored.

This series of storage experiments have given preliminary confirmation that SPME fibers can be used for field sampling of all of the tested compounds, with the exception of DCE, provided that fibers are properly capped and stored and that analysis

by GC is performed within 24 hours. Although these results indicate that storage of the SPME fibers prior to analysis is a viable option, more testing is needed to expand the parameters of these results. This experiment provided the basis for the subsequent set of tree core sampling at the Kellwood Site (OU2) of the Riverfront Superfund site in New Haven, Missouri.

### 4.3. IN-PLANTA FIELD SAMPLING

Tree coring and SPME sampling of five separate trees was conducted at the Kellwood Site (OU2) in New Haven, Missouri. This site has been previously studied by Schumacher, Struckhoff, and Burken [12]. During their investigation PCE was detected in native trees on the contaminated site and in poplar cuttings planted on the site.

Information about the five trees sampled in the current study is given in Table 4.4.

Table 4.4. Trees sampled by SPME analysis at Kellwood Site.

| Identifier | Previous Identifier | Type   | Height |
|------------|---------------------|--------|--------|
| JGB1       | GS03                | Poplar | 10 ft  |
| JGB2       | GS 11,13            | Poplar | 10 ft  |
| JGB3       | TK02                | Poplar | 20 ft  |
| JBG4-1     | JS72                | Poplar | 50 ft  |
| JGB4-2     | JS72                | Poplar | 50 ft  |
| JGB5       |                     | Willow | 20 ft  |

The parameters for each SPME sample are given in Table 4.5. All SPME samples were conducted using a retraction length of 0.5 cm with the exception of the willow tree identified as JGB5. This tree was tested previously with no detection of contaminants although it is believed to lie near the suspected plume boundaries. The tree was sampled

using a full exposure of the CAR/PDMS SPME fiber to give the best possible chance of detection if contaminants were indeed present. Figure 4.7 shows a photograph taken at the Kellwood Site demonstrating the use of the *in-planta* sampler with the SPME device.

Table 4.5. TWA-SPME parameters for *in-planta* sampling at Kellwood Site.

| Identifier | Retraction (Z) | Sampling Time |
|------------|----------------|---------------|
| JGB1       | 0.5 cm         | 72 minutes    |
| JGB2       | 0.5 cm         | 72 minutes    |
| JGB3       | 0.5 cm         | 72 minutes    |
| JGB4-1     | 0.5 cm         | 71 minutes    |
| JGB4-2     | 0.5 cm         | 71 minutes    |
| JGB5       | Full exposure  | 89 minutes    |



Figure 4.7. *In-planta* sampler and SPME device during sampling at Kellwood Site.

Results of the tree core and SPME sampling are given for TCE in Figure 4.8 and PCE in Figure 4.9. For every tree core analyzed, the corresponding SPME sample showed higher detection. The ratio of tree core to SPME peak responses is given in Table 4.6. Sampling with the SPME fibers resulted in levels of detection at a minimum

of 6 times higher for TCE and 5 times higher for PCE when detection was achieved. The detection of PCE by SPME sampling from tree JGB2 reached the upper detection limit of the GC detector and was considered to be non-linear.

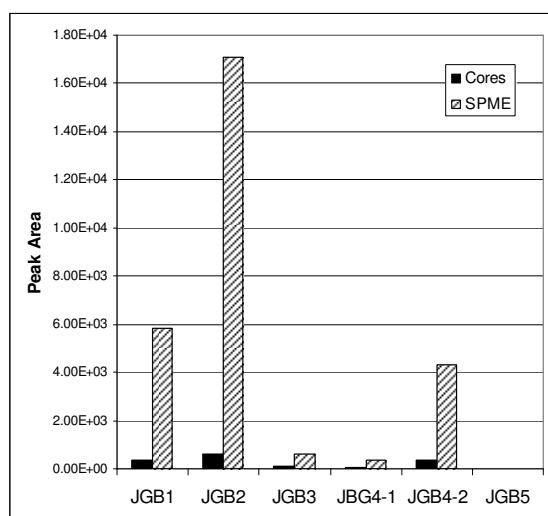

Figure 4.8. Field sampling results for TCE detection. SPME results for sample JGB2 indicate non-linearity.

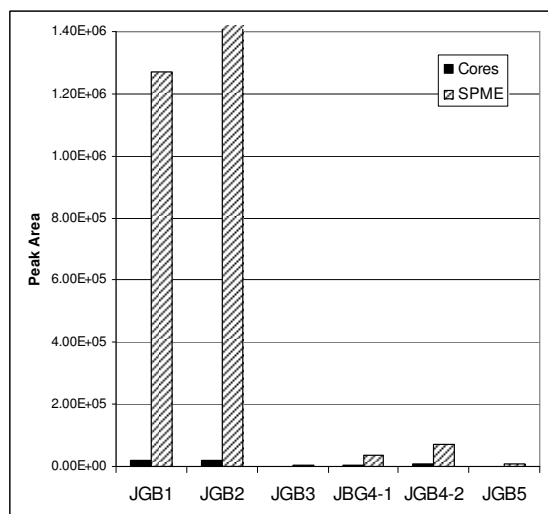

Figure 4.9. Field sampling results for PCE detection. SPME results for sample JGB2 indicate non-linearity.

Table 4.6. Ratios of SPME to tree core peak responses demonstrating increased detection with SPME.

| Identifier | SPME:Core Ratio |            |
|------------|-----------------|------------|
|            | TCE             | PCE        |
| JGB1       | 16:1            | 60:1       |
| JGB2       | 28:1            | 234:1      |
| JGB3       | 6:1             | 5:1        |
| JBG4-1     | 7:1             | 12:1       |
| JGB4-2     | 12:1            | 11:1       |
| JGB5       | 0:0             | $\infty$ * |

\* Non-detect for core analysis

Samples taken from tree JGB5 showed no detection of TCE either by tree core or by SPME. There was also no detection of PCE by tree core from tree JGB5, however PCE was detected in this tree by SPME. The tree JBG5 had been previously sampled via tree coring repeatedly with no detections. This indicates that SPME devices are able to attain considerably lower detection limits than tree core sampling. This was again exhibited in tree JGB3, which had no detection of PCE in the tree core but showed PCE by SPME sampling.

The repeated instances of higher detection of TCE and PCE by SPME sampling verses tree coring shown in these results indicate that SPME technology has the potential to be a superior sampling technique to tree core sampling. SPME devices have the advantage of lower detection limits and less time lost for sample equilibration prior to analysis. SPME fibers are also capable of detecting whole families of compounds with a single sample. In this sampling event, the target contaminant, PCE, was detected along with its daughter product of TCE. In this way, the presence of a broad range of metabolites can be determine while sampling for a target contaminant all with a single analysis. All of these benefits make SPME technology an attractive alternative to tree

core sampling. With further research, SPME techniques could be widely used to compliment or even replace tree coring for detection of chlorinated solvents in vegetative systems.



## 5. CONCLUSIONS AND RECOMMENDATIONS

### 5.1. CONCLUSIONS

Overall these experiments were successful in demonstrating the potential for SPME sampling *in-planta* for chlorinated VOCs. The following specific conclusions were generated.

- Sampling rate experiments were successfully conducted and mass loading profiles were determined. It was demonstrated that uptake is linear for most compounds in the chloromethane, chloroethane, and chloroethene groups using TWA methods. Mass loading profiles for 1,2-dichloroethane and 1,1,2,2-trichloroethane border on linear.
- The SPME CAR/PDMS fibers are not suited for detection of the chlorobenzene group of chlorinated solvents.
- Storage tests were successfully conducted, showing that the SPME device can be stored for up to 24 hours after sampling without significant losses for all compounds except dichloromethane. At 48 hours of storage, only chloroform, carbon tetrachloride, and trichloroethene were retained at 100% on the SPME fiber. All other compounds showed significant losses at 48 hours of storage.
- Field sampling using the new SPME *in-planta* sampler demonstrated the use of SPME devices as a substitute for tree core sampling. Lower detection limits were shown with the SPME device over tree core sampling.

These results suggest that analysis with SPME devices can also be accomplished in the field with a portable GC/MS for real-time data collection. These achievements demonstrate that SPME devices can be successfully used for detection of certain

chlorinated solvents in vegetative systems. Also demonstrated by this work is the vast potential of SPME sampling techniques for use with a wide variety of organic substrates for the detection of volatile organic compounds should partitioning relationships become more fully understood with further study.

## 5.2. RECOMMENDATIONS

**5.2.1. Future Work.** Further study of the sampling rates of these compounds by SPME fibers is needed for the full-scale use of the SPME device to quantify contaminant concentration and availability in phytoremediation systems. By incorporating diffusion and partitioning relationships, a model for contaminant mass loading on the SPME fiber may be developed. The temperature dependence of mass loading rates as well as the source of non-linearity in uptake rates may be identified.

Also to be further investigated is the variation in uptake rates of certain compounds with changes in diffusion path length. Some results indicate a departure from the expected linearity of sampling rate with increased diffusion path length. This inconsistency with theory can be more fully explored.

The application of SPME fibers for detection of other common pollutants may also be explored. In addition, *in-planta* samplers suited to other types of vegetation, such as grasses or aquatic species, may be developed. Procedures for field sampling can be further refined to determine optimum parameters such as bore-hole depth and diameter, exposure time, or bore-hole location on the tree trunk. Finally, other options for storage methods may be explored such as storage containers, sample retention times, or environmental parameters such as temperature or pressure.

**5.2.2. In-Planta Sampler Improvements.** A possible modification to the design of the *in-planta* sampler would provide a disposable seal. This improvement would eliminate concern of degradation of the quality of the seal over time and build-up of contaminant on the sealing materials over time creating cross-contamination potential. By changing the shape of the base of the sampler to mimic the shape of the top of a 22-mL vial, the crimp tops and septum used for these types of vials could be used on the sampler as a seal and as support for the fiber. The suggested design is shown in Figure 5.1.

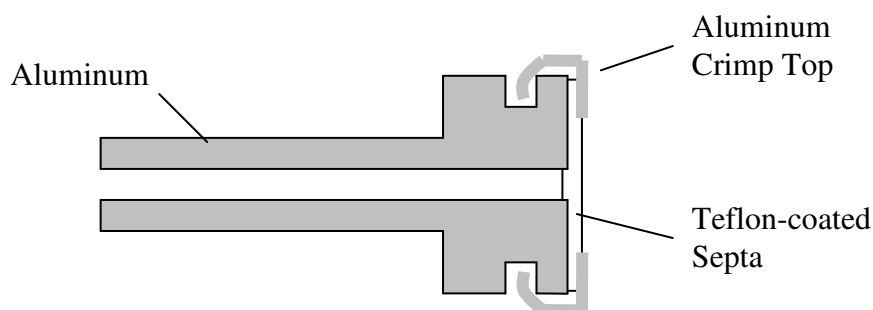

Figure 5.1. Design improvement for *in-planta* sampler.

Another addition for the *in-planta* sampler would allow sampling of trees for extended periods of time without fear of damage to the fiber from weather or wildlife. Extended sampling times would be useful to confirm the absence of a contaminant in an area suspected to be contaminated, or to continue data collection efforts in an ongoing remediation after contaminant levels have fallen below detection limits of other methods. To provide this protection a cup-shaped cover could be placed over the SPME fiber and sampler after it is in place in the tree. The cover could be fitted with straps that wrap

around the tree and hold the cover in place. A thick layer of foam around the rim of the cover could provide a seal to keep out wind and rain.

If implemented, these improvements could help to create an *in-planta* SPME sampler that is versatile and easy to use, while maintaining sample integrity. An improved *in-planta* SPME sampler combined with enhanced understanding of mass loading rates on the SPME fiber could create a solution for the adaptation of SPME technology for today's leading environmental concerns.

APPENDIX A.  
PHYSICAL PROPERTIES

|                           | Molecular Weight (g/mol) | VP                | Aqueous             |                     |                         | Diffusivity                         |                              |
|---------------------------|--------------------------|-------------------|---------------------|---------------------|-------------------------|-------------------------------------|------------------------------|
|                           |                          | at 25°C           | Solubility          | $K_h$               | $K_{ow}$                | in air                              | Diffusivity                  |
|                           |                          | -logP (atm)       | at 25°C (mg/L)      | at 25°C (L atm/mol) | at 25°C (log $K_{ow}$ ) | at 25°C. 1 atm (cm <sup>2</sup> /s) | in wood (cm <sup>2</sup> /s) |
| <b>Chloromethanes</b>     |                          |                   |                     |                     |                         |                                     |                              |
| Dichloromethane           | 84.9                     | 0.23 <sup>a</sup> | 19,400 <sup>b</sup> | 2.5 <sup>b</sup>    | 1.25 <sup>b</sup>       | 0.11 <sup>c</sup>                   |                              |
| Chloroform                | 119.4                    | 0.59 <sup>a</sup> | 7,500 <sup>b</sup>  | 4.1 <sup>b</sup>    | 1.97 <sup>b</sup>       | 0.091 <sup>c</sup>                  |                              |
| Carbon Tetrachloride      | 15.8                     | 0.82 <sup>a</sup> | 790 <sup>b</sup>    | 29 <sup>b</sup>     | 2.83 <sup>b</sup>       | 0.082 <sup>c</sup>                  |                              |
| <b>Chloroethanes</b>      |                          |                   |                     |                     |                         |                                     |                              |
| 1,2-Dichloroethane        | 99.0                     | 1.04 <sup>a</sup> | 8,700 <sup>b</sup>  | 1.18 <sup>b</sup>   | 1.48 <sup>b</sup>       | 0.091 <sup>c</sup>                  |                              |
| 1,1,2-Trichloroethane     | 133.4                    |                   | 4,400 <sup>b</sup>  | 0.92 <sup>b</sup>   | 1.89 <sup>b</sup>       | 0.082 <sup>c</sup>                  |                              |
| 1,1,2,2-Tetrachloroethane | 167.9                    | 2.06 <sup>a</sup> | 3,100 <sup>a</sup>  | 0.48 <sup>a</sup>   | 2.39 <sup>a</sup>       | 0.075 <sup>c</sup>                  | 0.68 <sup>d</sup>            |
| <b>Chloroethenes</b>      |                          |                   |                     |                     |                         |                                     |                              |
| cis-1,2-Dichloroethylene  | 96.9                     |                   | 3,500 <sup>b</sup>  | 7.4 <sup>b</sup>    | 1.86 <sup>b</sup>       | 0.094 <sup>c</sup>                  |                              |
| Trichloroethylene         | 131.4                    | 1.01 <sup>a</sup> | 1,100 <sup>b</sup>  | 11.6 <sup>b</sup>   | 2.42 <sup>b</sup>       | 0.083 <sup>c</sup>                  | 1.14 <sup>d</sup>            |
| Perchloroethylene         | 165.8                    | 1.60 <sup>a</sup> | 150 <sup>b</sup>    | 26.9 <sup>b</sup>   | 3.4 <sup>b</sup>        | 0.076 <sup>c</sup>                  | 0.31 <sup>d</sup>            |
| <b>Chlorobenzenes</b>     |                          |                   |                     |                     |                         |                                     |                              |
| Chlorobenzene             | 112.6                    | 1.80 <sup>a</sup> | 390 <sup>b</sup>    | 4.5 <sup>b</sup>    | 2.84 <sup>b</sup>       | 0.079 <sup>c</sup>                  |                              |
| 1,2-Dichlorobenzene       | 147.0                    | 2.71 <sup>a</sup> | 92 <sup>b</sup>     | 2.8 <sup>b</sup>    | 3.43 <sup>b</sup>       | 0.073 <sup>c</sup>                  |                              |
| 1,2,4-Trichlorobenzene    | 181.4                    | 3.21 <sup>a</sup> |                     | 3.0 <sup>b</sup>    |                         | 0.068 <sup>c</sup>                  |                              |

a [29]

b [30]

c Calculated by method of Fuller et al. (1966)

d [31]

APPENDIX B.  
TWA-SPME SAMPLING PROCEDURE

## Time-weighted Average Solid-phase Microextraction Sampling Procedure

1. Check GC oven to ensure column is properly installed and connected to the front inlet and  $\mu$ ECD detector
2. Install SPME injection sleeve and Merlin septa
  - a. Check the front inlet temperature to ensure components are safe to touch
  - b. Turn off the front inlet heating if necessary and either allow temperature to cool or proceed with caution and avoid direct contact with components
  - c. Turn off front inlet pressure
  - d. Unscrew and remove upper septa nut from the front inlet
  - e. Remove the blue septa
  - f. Unscrew the lower injection sleeve nut
  - g. Carefully pull the lower nut up and to the left, being cautious not to break the injection sleeve
  - h. Remove the injection sleeve using tweezers and store in plastic holder
  - i. Insert SPME injection sleeve into inlet, turning the sleeve if necessary thread the column through the sleeve
  - j. Press down on the top of the injection sleeve until resistance is felt
  - k. Replace the lower nut over injection sleeve and screw on while pressing down
  - l. Tighten lower nut
  - m. Check Merlin septa to ensure that the metal bracket is attached to lower side of the inlet port
  - n. Insert Merlin septa into the injection port and press into place
  - o. Turn on front inlet pressure
  - p. Screw on Merlin upper nut slowly until front inlet pressure spikes up and is maintained
  - q. Tighten Merlin upper nut one additional tick mark using marking on the top of the nut
3. Load GD method in Chemstation software
4. Allow front detector signal to stabilize below 600 Hz
5. Condition PDMS fiber
  - a. Load a PDMS SPME fiber into the holder
  - b. Adjust the holder to the 1.6 position
  - c. Extend the fiber, inspect for damage, and retract into needle housing
  - d. Insert the fiber into the front inlet, heated to 250°C, until holder rests on septa nut
  - e. Fully extend the fiber inside the inlet port and position screw on the holder into notch
  - f. Allow fiber to condition for at least 5 minutes
6. Prepare PDMS solution sample



- a. Transfer approximately 1 mL of the appropriate diluted stock solution into a 22-mL vial using a 1-mL disposable pipet
  - b. Cap vial
  - c. Rotate vial, coating the bottom inch of the vial with solution in equilibrate headspace
  - d. Pre-pierce septa with needle before inserting SPME fiber
7. Run 2 equilibrium sampling tests
- a. Modify sample name in Chemstation software
  - b. After conditioning is complete, retract the fiber into the needle housing
  - c. Set timer for 4 minutes
  - d. Remove fiber from front inlet
  - e. Quickly transfer fiber from inlet to sample vial
  - f. Inset fiber through septa on sample vial until holder rests on the vial cap
  - g. Expose fiber by pressing down the plunger on holder and position screw on holder into notch
  - h. Start timer
  - i. When timer is finished, retract the fiber into the needle housing
  - j. Pull fiber from the sample vial and transfer to GC
  - k. Inset fiber into front inlet until holder rests on septa nut
  - l. Expose fiber by pressing down the plunger on holder and position screw on holder into notch
  - m. Press start on GC control panel
  - n. Allow fiber to condition in front inlet for at least 5 minutes
8. If results of two equilibrium tests give similar results, continue to TWA sampling with Carboxene fiber
9. Condition Carboxene fiber
- a. Load a Carboxene SPME fiber into the holder – When removing or replacing Teflon® cap, inset the needle straight into cap, do not twist cap or fiber
  - b. Adjust the holder to the 4.0 position
  - c. Extend the fiber, inspect for damage, and retract into needle housing
  - d. Adjust position of black O-ring on holder to desired position for fiber retraction by aligning center of screw with edge of tape and positioning O-ring at top of screw
  - e. Insert the fiber into the front inlet, heated to 250°C, until holder rests on septa nut
  - f. Fully extend the fiber inside the inlet port and position screw on the holder into notch
  - g. Allow fiber to condition for at least 5 minutes
10. Time-weighted average (TWA) sampling
- a. Modify sample name in Chemstation software
  - b. After conditioning is complete, retract the fiber into the needle housing stopping at the pre-set retraction length

- c. Set timer for appropriate sampling time
- d. Remove fiber from front inlet
- e. Quickly transfer fiber from inlet to sample vial
- f. Inset fiber through septa on sample vial until holder rests on the vial cap
- g. Start timer
- h. When timer is finished, pull fiber from the sample vial and transfer to GC
- i. Inset fiber into front inlet until holder rests on septa nut
- j. Expose fiber by pressing down the plunger on holder and position screw on holder into notch
- k. Press start on GC control panel
- l. Allow fiber to condition in front inlet for at least 5 minutes
- m. Repeat TWA sampling procedure for each sampling time desired

11. When TWA sampling is complete, repeat 2 equilibrium sampling runs

APPENDIX C.  
TWA-SPME SAMPLING RESULTS

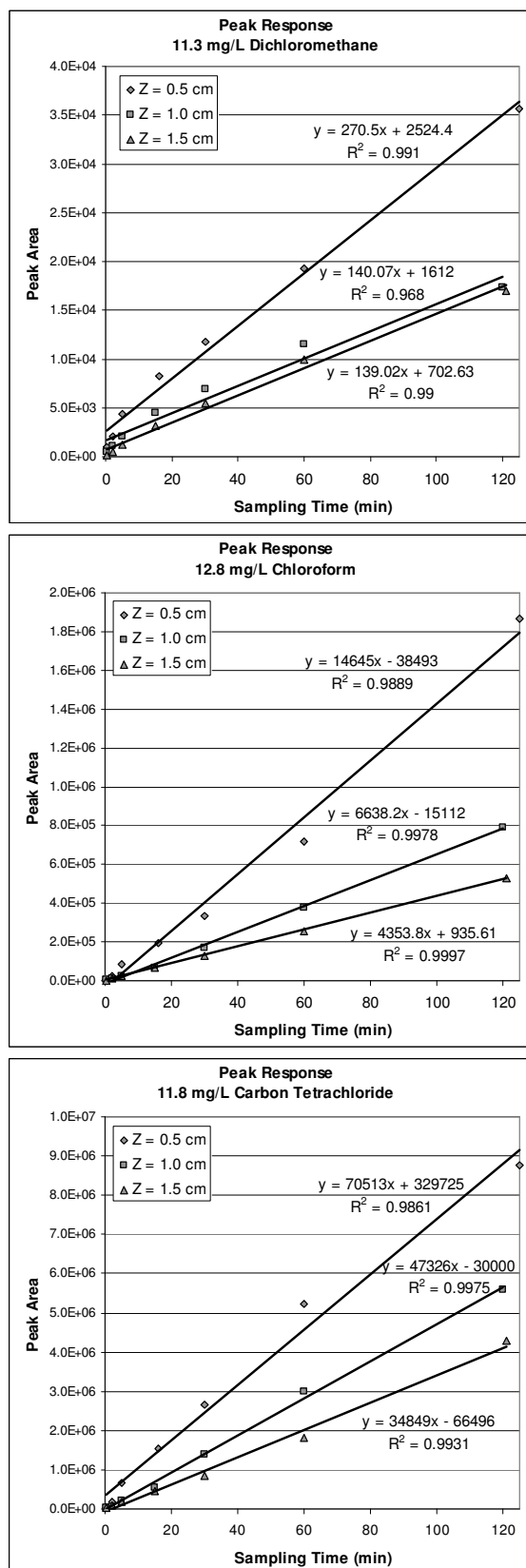

Figure C.1. TWA-SPME sampling results; chloromethanes grouped by compound.  
 $PA_i/PA_0 > 0.93$  for all data sets.

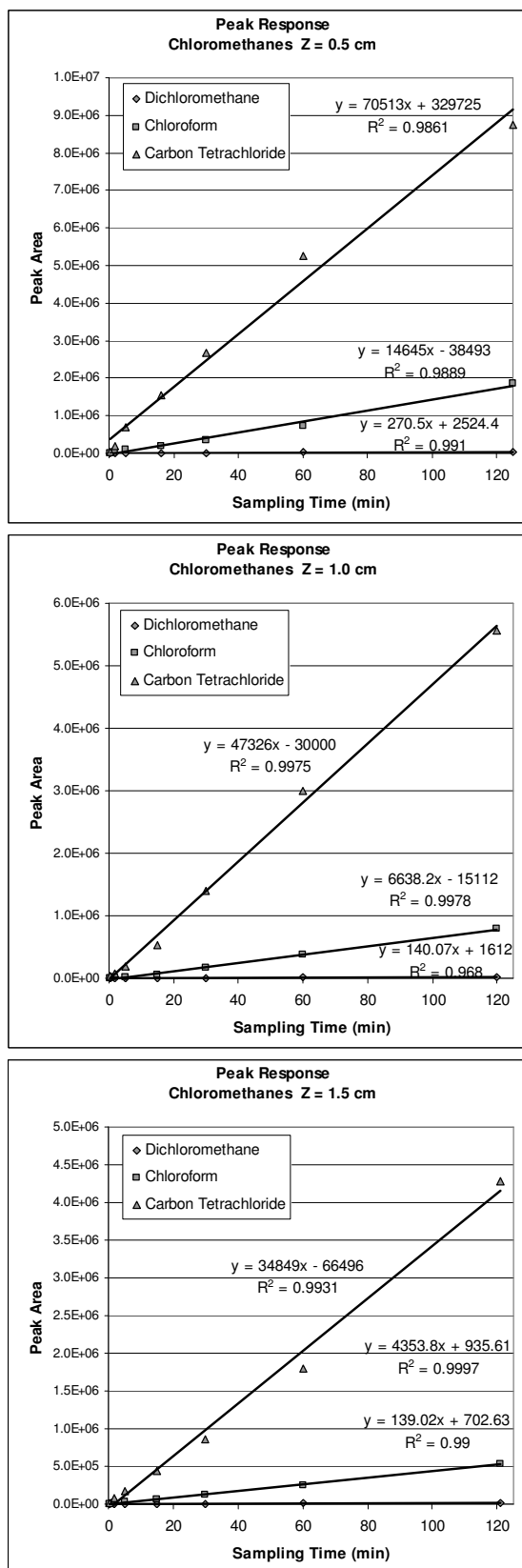

Figure C.2. TWA-SPME sampling results; chloromethanes grouped by retraction length (Z).  $PA_f/PA_0 > 0.93$  for all data sets.

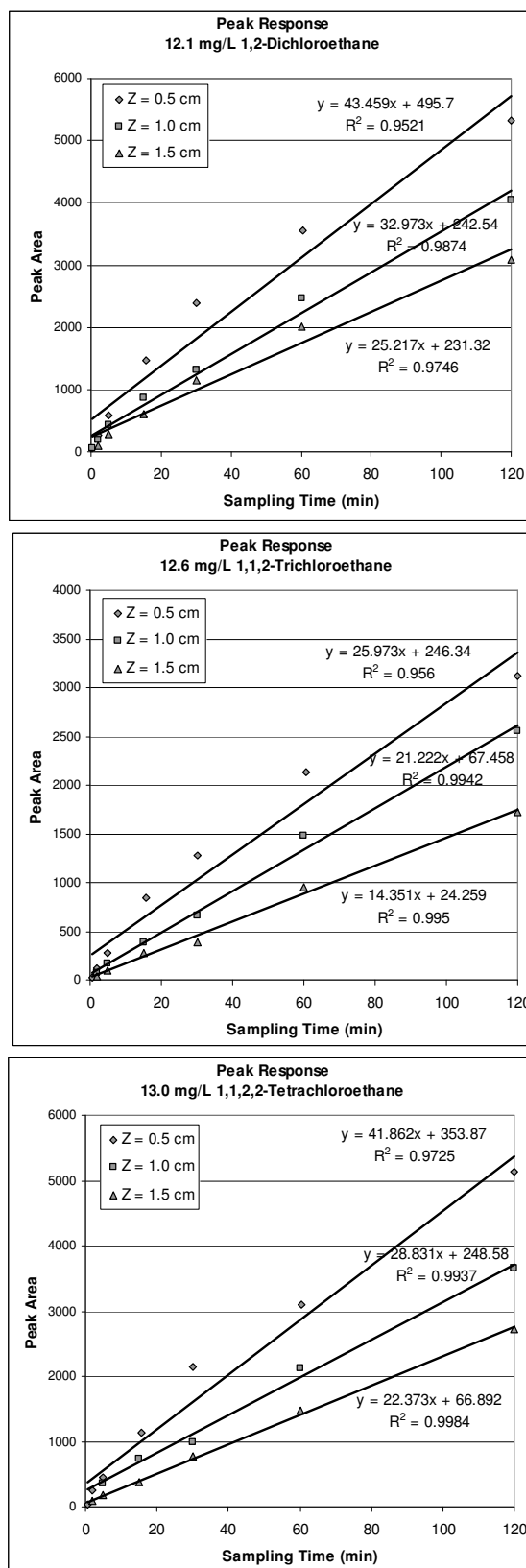

Figure C.3. TWA-SPME sampling results; chloroethanes grouped by compound.  
 $PA_i/PA_0 > 0.88$  for all data sets.

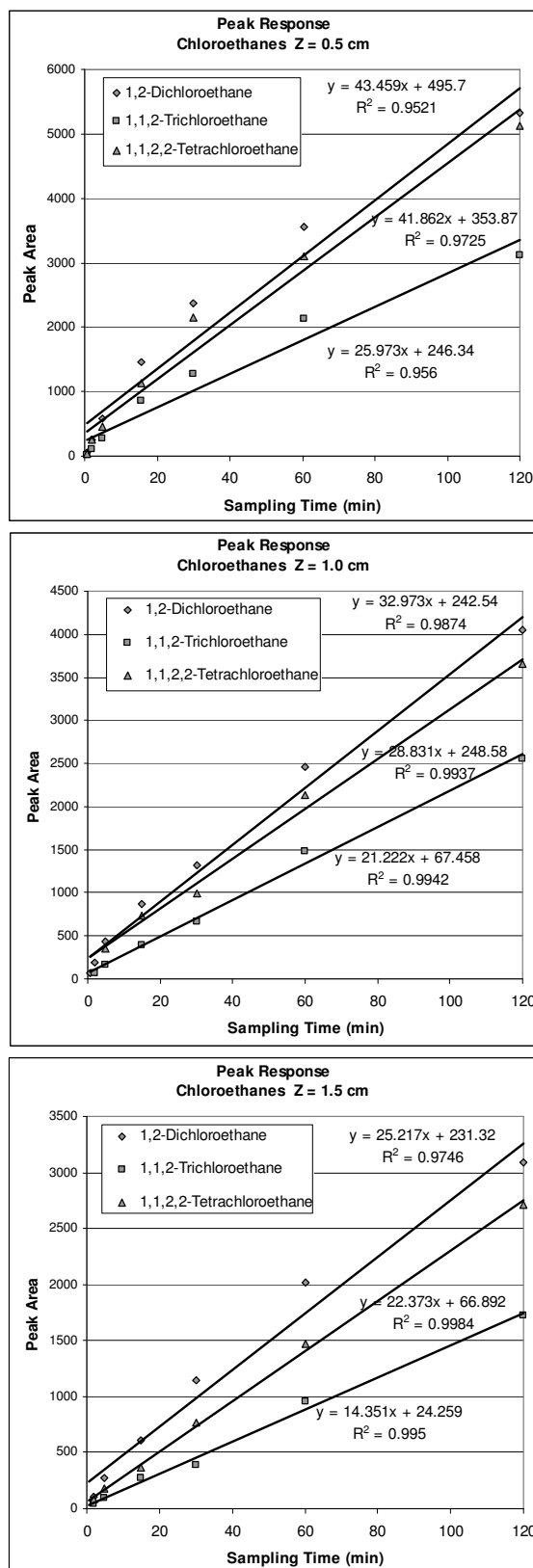

Figure C.4. TWA-SPME sampling results; chloroethanes grouped by retraction length (Z).  $PA_f/PA_0 > 0.88$  for all data sets.

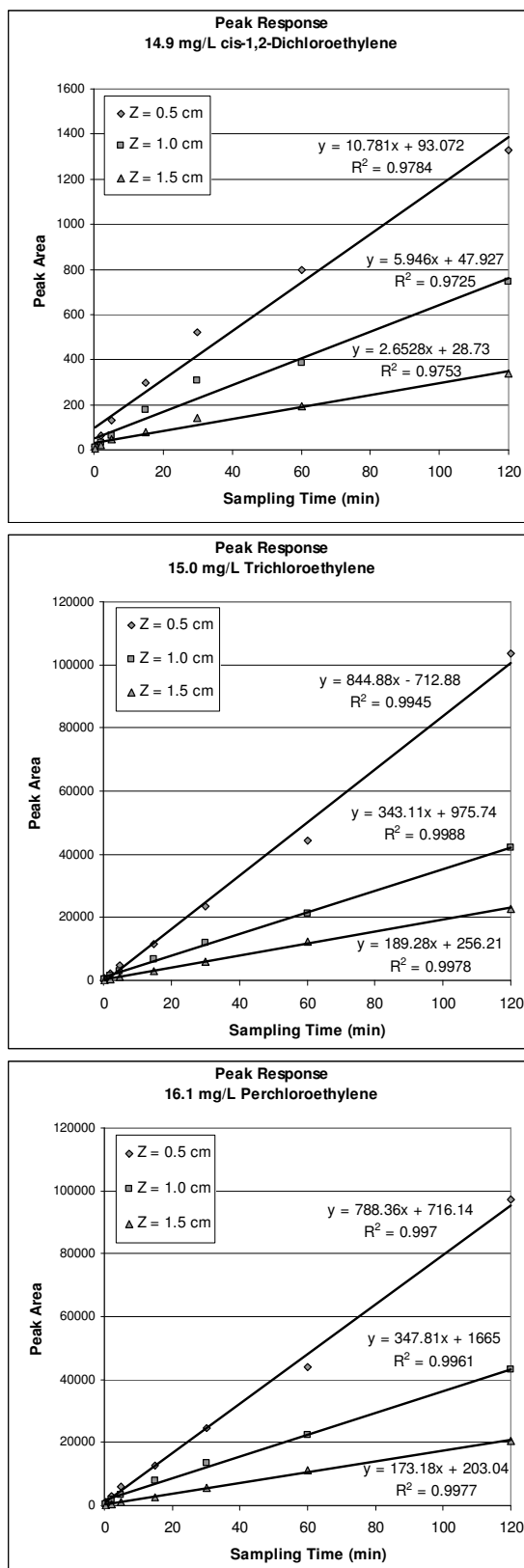

Figure C.5. TWA-SPME sampling results; chloroethenes grouped by compound.  
 $PA_i/PA_0 > 0.99$  for all data sets.



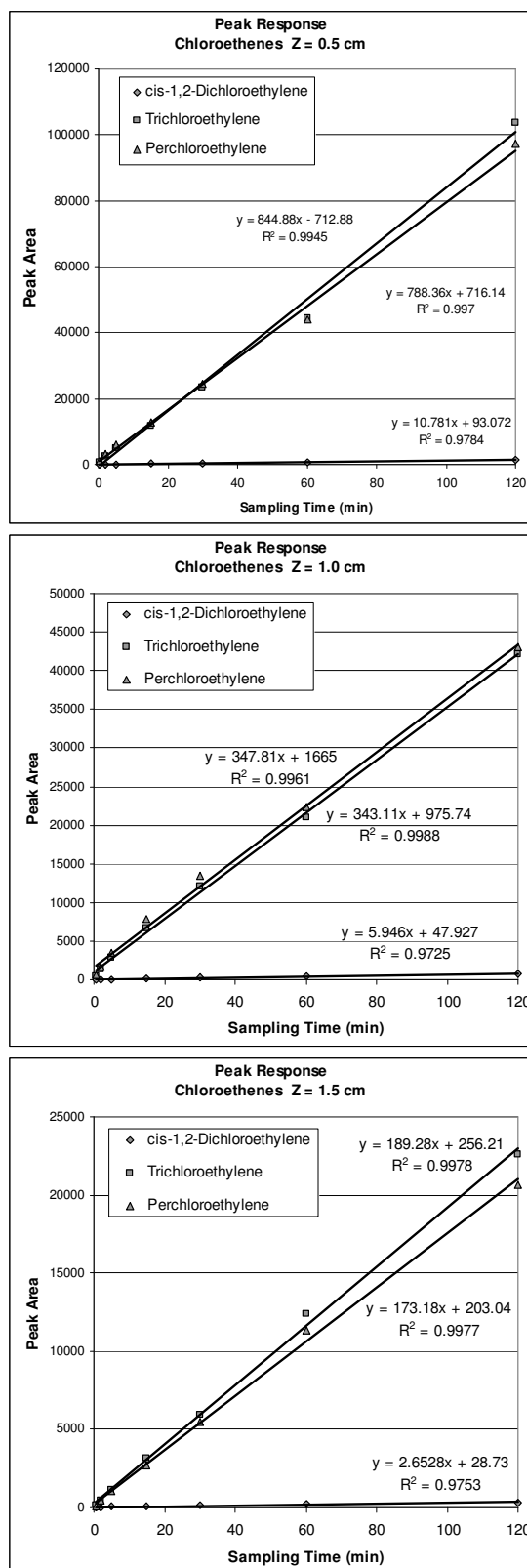

Figure C.6. TWA-SPME sampling results; chloroethenes grouped by retraction length (Z).  $PA_f/PA_0 > 0.99$  for all data sets.

## BIBLIOGRAPHY

- [1] J.L. Schnoor, L.A. Licht, S.C. McCutcheon, N.L. Wolfe, and L.H. Carreira, "Phytoremediation of Organic and Nutrient Contaminants," *Environmental Science & Technology*, Vol. 29, No. 7, Pp. 318A-323A (1995).
- [2] D.A. Vroblesky, C.T. Nietch, and J.T. Morris, "Chlorinated Ethenes from Groundwater in Tree Trunks," *Environmental Science & Technology*, Vol. 33, No. 3, Pp. 510-515 (1999).
- [3] X. Ma and J.G. Burken, "VOCs Fate and Partitioning in Vegetation: Use of Tree Cores in Groundwater Analysis," *Environmental Science & Technology*, Vol. 36, No. 21, Pp. 4663-4668 (2002).
- [4] X. Ma and J.G. Burken, "TCE Diffusion to the Atmosphere in Phytoremediation Applications," *Environmental Science & Technology*, Vol. 37, No. 11, Pp. 2534-2539 (2003).
- [5] P. Mayer, J. Tolls, J.L.M. Hermens, and D. MacKay, "Equilibrium Sampling Devices," *Environmental Science & Technology*, Vol. 37, No. 9, Pp. 185A-191A (2003).
- [6] N. Yassaa and J. Williams, "Analysis of enantiomeric and non-enantiomeric monoterpenes in plant emissions using portable dynamic air sampling/solid-phase microextraction (PDAS-SPME) and chiral gas chromatography/mass spectrometry," *Atmospheric Environment*, Vol. 39, Pp. 4875-4884 (2005).
- [7] A.M. Santos, T. Vasconcelost, E. Mateus, M.H. Farrall, M.D.R. Gomes da Silva, M.R. Paiva, and M. Branco, "Characterization of the volatile fraction emitted by phloems of four pinus species by solid-phase microextraction and gas chromatography-mass spectrometry," *Journal of Chromatography*, Vol 1105, Pp. 191-198 (2006).
- [8] G.G. Briggs, R.H. Bromilow, and A.A. Evans, "Relationships between Lipophylicity and Root Uptake and Translocation of Non-ionised Chemicals by Barley," *Pesticide Science*, Vol. 13, Pp. 495-504 (1982).
- [9] J.G. Burken and J.L. Schnoor, "Predictive Relationships for Uptake of Organic Contaminants by Hybrid Poplar Trees," *Environmental Science & Technology*, Vol. 32, No. 21, Pp. 3379-3385 (1998).
- [10] G.C. Struckhoff, J.G. Burken, and J.G. Schumacher, "Vapor-phase Exchange of Perchloroethene between Soil and Plants," *Environmental Science & Technology*, Vol 39, No 6, Pp. 1563-1568 (2005).

- [11] L.A. Newman, S.E. Strand, N. Choe, J. Duffy, G. Ekuan, M. Ruszaj, B.B. Shurtleff, J. Wilmoth, P. Heilman, and M.P. Gordon, "Uptake and Biotransformation of Trichloroethylene by Hybrid Poplars," *Environmental Science & Technology*, Vol. 31, No. 4, Pp. 1062-1067 (1997).
- [12] J.G. Schumacher, G.C. Struckoff, and J.G. Burken, "Assessment of Subsurface Chlorinated Solvent Contamination Using Tree Cores at the Front Street Site and a Former Dry Cleaning Facility at the Riverfront Superfund Site, New haven, Missouri, 1999-2003," *U.S. Geological Survey Scientific Investigations Report*, 2004-5049.
- [13] D.A. Vroblesky, B.D. Clinton, J.M. Vose, C.C. Casey, G.J. Harvey, and P.M. Bradley, "Ground Water Chlorinated Ethenes in Tree Trunks: Case Studies, Influence of Recharge, and Potential Degradation Mechanism," *Ground Water Monitoring & Remediation*, Vol. 24, No. 3, Pp. 124-138 (2004).
- [14] C.T. Nietch, J.T. Morris, and D.A. Vroblesky, "Biophysical Mechanisms of Trichloroethene Uptake and Loss in Baldcypress Growing in Shallow Contaminated Groundwater," *Environmental Science & Technology*, Vol. 33, No. 17, Pp. 2899-2904 (1999).
- [15] X. Ma and J.G. Burken, "TCE Diffusion to the Atmosphere in Phytoremediation Applications," *Environmental Science & Technology*, Vol. 37, No. 11, Pp. 2534-2539 (2003).
- [16] X. Ma and J.G. Burken, "Modeling of TCE Diffusion to the Atmosphere and Distribution on Plant Stems," *Environmental Science & Technology*, Vol. 38, No. 17, Pp. 4580-4586 (2004).
- [17] K.K. Baduru, S. Trapp, and J.G. Burken, "Direct Measurement of VOC Diffusivities in Tree Tissues: Impacts on Tree-Based Phytoremediation and Plant Contamination," *Environmental Science & Technology*, Vol. 42, No. 4, Pp. 1268-1275 (2008).
- [18] J.A. Koziel and J. Pawliszyn, "Air Sampling and Analysis of Volatile Organic Compounds with Solid Phase Microextraction," *Journal of the Air & Waste Management Association*, Vol. 51, Pp. 173-184 (2001).
- [19] G. Vas and K. Vekey, "Solid-phase microextraction: a powerful sample preparation tool prior to mass spectrometric analysis," *Journal of Mass Spectrometry*, Vol. 39, Pp. 233-254 (2004).

- [20] A. Khaled and J. Pawliszyn, "Time-Weighted Average Sampling of Volatile and Semi-Volatile Airborne Organic Compounds by the Solid-Phase Microextraction Device," *Journal of Chromatography*, Vol. 892A, Pp. 455-467 (2000).
- [21] Y. Chen and J. Pawliszyn, "Time-Weighted Average Passive Sampling with a Solid-Phase Microextraction Device," *Analytical Chemistry*, Vol. 75, Pp. 2004-2010 (2003).
- [22] Y. Chen and J. Pawliszyn, "Solid-Phase Microextraction Field Sampler," *Analytical Chemistry*, Vol. 76, Pp. 6823-6828 (2004).
- [23] T.L. Ter Laak, P. Mayer, F.L.M. Busser, H.J.C. Klamer, and J.L.M. Hermens, "Sediment Dilution Methods to Determine Sorption Coefficients of Hydrophobic Organic Chemicals," *Environmental Science & Technology*, Vol. 39, No. 11, Pp. 4220-4225 (2005).
- [24] S.V. Skaates, A. Ramaswami, and L.G. Anderson, "Transport and fate of dieldrin in poplar and willow trees analyzed by SPME," *Chemosphere*, Vol. 61, Pp. 85-91 (2005).
- [25] C.N. Legind, U. Karlson, J.G. Burken, F. Reichenberg, and P. Mayer, "Determining Chemical Activity of (Semi)volatile Compounds by Headspace Solid-Phase Microextraction," *Analytical Chemistry*, Vol. 79, Pp. 2869-2876 (2007).
- [26] B.H. Hwang and M.R. Lee, "Solid-phase microextraction for organochlorine pesticide residues analysis in Chinese herbal formulations," *Journal of Chromatography*, Vol. 898, Pp. 245-256 (2000).
- [27] H.L. Lord, M. Moder, P. Popp, and J.B. Pawliszyn, "In vivo study of triazine herbicides in plants by SPME," *Analyst*, Vol. 129, Pp. 107-108 (2004).
- [28] "Kellwood Site (OU-2)," *USGS Missouri Water Science Center*, Ed. J.G. Schumacher, 22 Mar 2004, United States Geological Survey, accessed 12 Feb 2009 <[http://mo.water.usgs.gov/epa/nh/RI\\_files/OU-2\\_Home\\_files/index.htm](http://mo.water.usgs.gov/epa/nh/RI_files/OU-2_Home_files/index.htm)>.
- [29] R.P. Schwarzenbach, P.M. Gschwend, and D.M. Imboden, *Environmental Organic Chemistry*, John Wiley & Sons: New York (1993).
- [30] C.N. Sawyer, P.L. McCarty, and G.F. Parkin, *Chemistry for Environmental Engineering and Science*, 5th Ed., McGraw-Hill: New York (2003).

- [31] K.K. Baduru, "Diffusivity and Partition of Selected Volatile Organic Compounds in Phytoremediation Applications," Master's Thesis, Missouri University of Science & Technology, Rolla, Missouri (2006).

## VITA

Emily Moore Sheehan was born on April 8, 1980 in St. Louis, Missouri. She graduated from Northwest High School in Cedar Hill, Missouri in 1998. She received a Bachelor of Science in Chemical Engineering from the University of Missouri - Rolla in 2004. As an undergraduate she was a member of the American Chemical Society, the American Institute of Chemical Engineers, the UMR Student Council, and Kappa Delta Sorority. She also participated in the cooperative education program by working as a Process Engineer for Monsanto Company and as a Process R&D Engineer for DuPont Protein Technologies. She continued as a graduate student at the University of Missouri - Rolla pursuing a Master of Science in Environmental Engineering. While working to complete her graduate studies she was employed as an Environmental Engineer for Boyle Engineering Corporation and Environmental Resources Management, Inc. She received a Master of Science in Environmental Engineering in May of 2009 from the Missouri University of Science and Technology.